

# ***Installation, Operating and Safety Manual*** **for Liquid Filter Housings and Filter Media**

***Over-The-Top® Design***



**Filtration Systems**

Division of Mechanical Mfg. Corporation

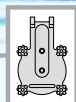

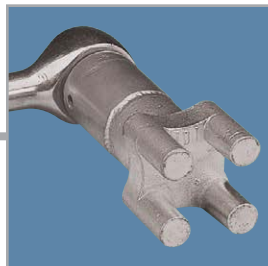

# Installation, Operating and Safety Manual

## for Liquid Filter Housings and Filter Media

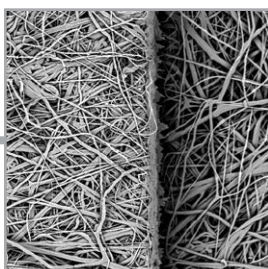
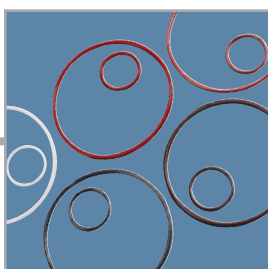
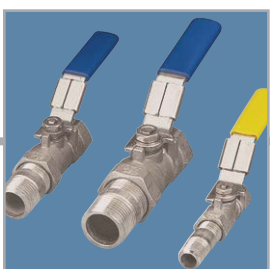
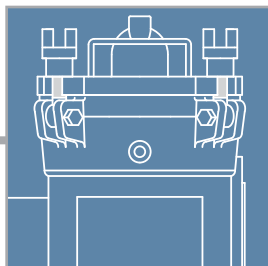

### **FILTER HOUSINGS**

- 2 Introduction
- 2 Standard Housing Features and Available Options
- 3 Product Identification
- 4 Component Parts Diagram

### **INSTALLATION AND OPERATION**

- 6 Safety Information
- 7 Installing the Filter Housing
- 9 Installing Filter Media
- 10 Operating Procedures
- 11 Filter Media Removal
- 12 Maintaining your Filter Housing
- 12 Troubleshooting

### **PARTS AND ACCESSORIES**

- 14 Replacement Hardware
- 14 Pressure Gauges, Drain Valves and Vent Valves
- 14 Adjustable Tripod Stands
- 16 Support and Accessory Baskets
- 18 Stands, Brackets & Housings for Miniature Housings
- 19 Replacement Inlet/Outlet Ball Valves & Parts
- 19 Replacement Housing Lids
- 19 Cartridge Chambers & Chamber Hardware
- 20 O-Rings and Gaskets

### **FILTER MEDIA**

- 21 *ACCUFIT*® Welded Expanded Media
- 23 *ACCUFIT*® Welded SuperBond®
- 24 *ULTRAFIT*® Welded
- 27 APX® High-Capacity Element
- 28 Filter Media Specifications

### **CUSTOMER SUPPORT**

- 30 Standard Terms & Conditions of Sale
- 31 Warranty / Limitations of Liability
- 31 Product Specifications / Intellectual Property Rights
- 32 Filter Housing Model Number Coding System

## INTRODUCTION

Thank you for selecting *Filtration Systems* equipment for your liquid filtration requirements. Our Liquid Filter Housings and Systems are designed for use with High Performance Filter Bags, Large Diameter Filter Elements Cartridge Filters, or Strainer Baskets. This Installation, Operating & Safety Manual was prepared by professionals at *Filtration Systems* who are concerned with your safety and satisfaction. By familiarizing yourself with this booklet, most of your questions about our products will be answered.

**IF YOU HAVE ANY QUESTIONS, OR NEED OUR ASSISTANCE,  
PLEASE DO NOT HESITATE TO CALL US AT (954) 572-2700.**

## STANDARD HOUSING FEATURES

- **Over-The-Top**<sup>®</sup> Design
- Built to ASME Code Standards
- Investment Cast Lid and Body
- Hinged Lid with Handle, Built-in Lid Stop, and Safety Detents
- Perforated T-316 S/S Support Basket with Longitudinal Taper
- Gauge Ports, Vent Ports, Drain Ports
- O-Ring Grooves Machined into Housing Lid (Buna-N standard)
- Available in 150 psi or 300 psi Maximum Working Pressure

## **Over-The-Top**<sup>®</sup> Housing Design

*Over-The-Top* housing design, featured on all *Filtration Systems* vessels, maximizes filtration performance by preventing bypass of unfiltered liquid. When the vessel is closed, the machined face of the lid compresses the top of the *Zero-Bypass*<sup>®</sup> bag collar, forming an absolute seal. As there is no 'dead-space' between the top of the bag and the housing lid, unfiltered liquid cannot accumulate in the housing, eliminating clean up of the vessel interior during change-out. The used bag, containing filtered solids, is simply removed and replaced with a clean filter bag.

## HOUSING OPTIONS

- T-316 SS Upgrade, Including S/S Lid Hardware
- Low-Profile, Horizontal Outlet
- Alternate Outlet Locations
- Modified Connections: R/F ANSI Flanges, NPT Threads, Sanitary Ferrules
- Cam and Groove Fittings
- Additional Ports
- Sanitary, Four Position Butterfly Valves
- Actuated Valves; Pneumatic or Electric
- **SAFESystem**<sup>®</sup> Safety Apparatus Filter Enhancement
- Dual-Valve Linkage Mechanism – DVLM™
- Common Drain Manifold – CDM™

## OPTIONAL FINISHES

- Interior Polished Sanitary Finish
- HALAR<sup>®</sup> Fluoropolymer Lining
- Epoxy Coating; Interior, Exterior, and Stand

## FILTER MEDIA OPTIONS

- High Performance Liquid Filter Bags
- Mesh or Micron Lined Baskets
- Perforated Strainer Baskets
- APX<sup>®</sup> Large Diameter Cartridge Elements

## ADDITIONAL OPTIONS & HOUSING ACCESSORIES

- Thermal Jackets; Two-Piece, Stainless Steel
- Ball Valve Lockout Assembly
- Liquid Displacers
- Drain Valves, Vent Valves and Pressure Gauges
- Assorted O-Ring Materials

## PRODUCT IDENTIFICATION

**Record the Model and Serial Number of your Filter Housing for ease of ordering spare parts.**

VESSEL MODEL NUMBER \_\_\_\_\_

SERIAL NUMBER(S) \_\_\_\_\_

YEAR BUILT (ASME CODE VESSELS) \_\_\_\_\_

FILTER BAG MODEL NUMBER AND MICRON RATING \_\_\_\_\_

### NOTICE

All *Filtration Systems* Filter Housings are stamped with a unique Serial Number that can be identified by our factory. Nameplates are permanently affixed to the pipe of each filter housing.

**Removal of the nameplate voids the product of any warranty and eliminates future identification of the product.**



**ASME Code Nameplate** identifies both the National Board Number and the Serial Number of the vessel. A “U” Stamp indicates that the Vessel has been designed and manufactured in accordance with the guidelines of ASME Code Section 8, Division 1. Limits of safe working pressures and temperatures are designated on the nameplate.

### NOTICE

**Any repair or modification of a housing with an ASME code plate voids the ASME certification of the housing.**



An **Industrial Grade Nameplate** identifies the Serial Number of the Vessel, as well as the safe limits of working pressure and temperature.



A **CE Plate** identifies the vessel as being designed and built in accordance with the European Pressure Equipment Directive. The Serial Number and limits of safe working pressures and temperatures are designated on the nameplate. Required for participating European member countries only.

# COMPONENT PARTS

## Over-The-Top® Design Individual Filter Housing

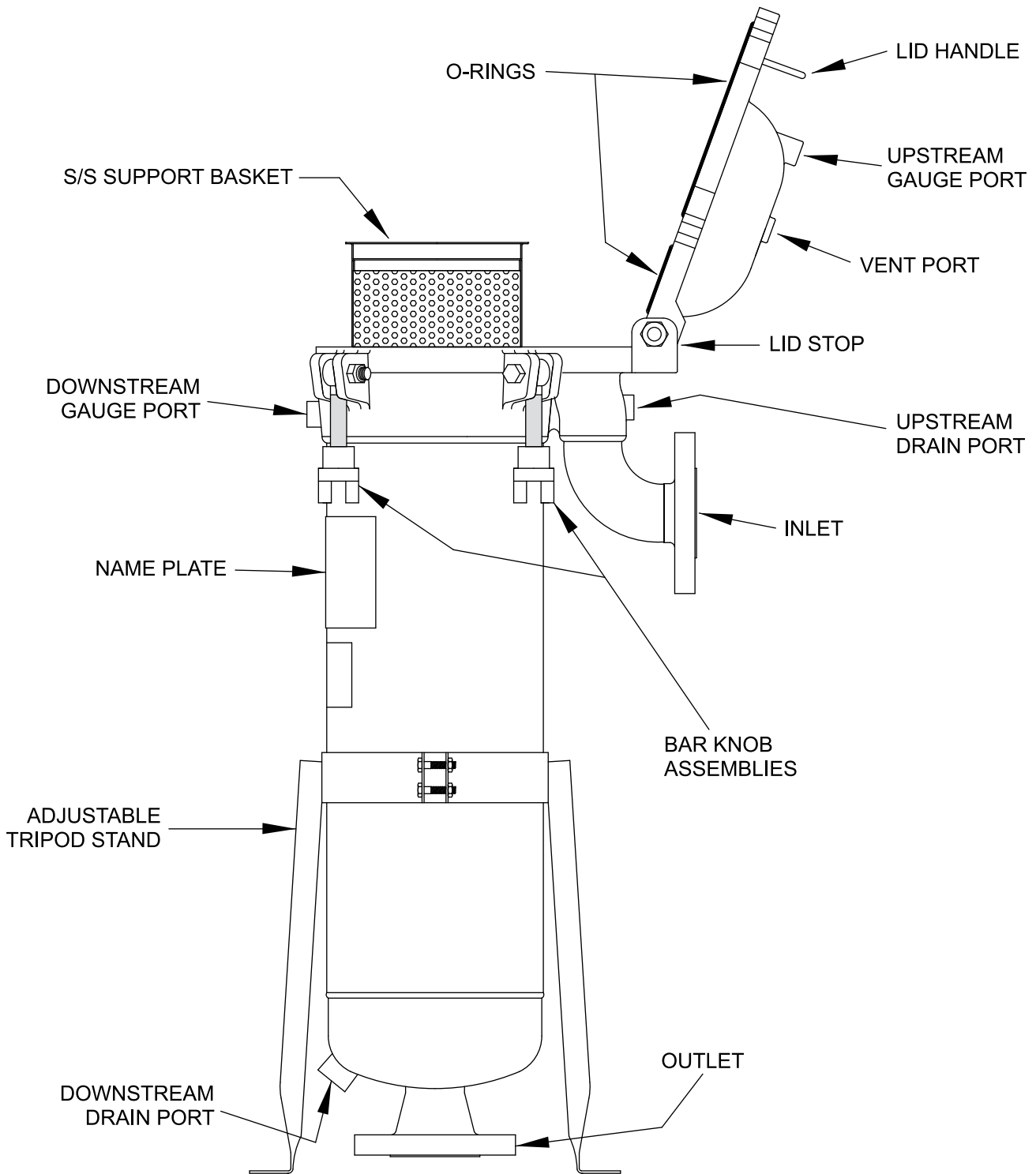

**Note: Refer to Product Brochure for specific type of connections and complete specifications.**

# COMPONENT PARTS

## Over-The-Top® Multi-Housing Filter System

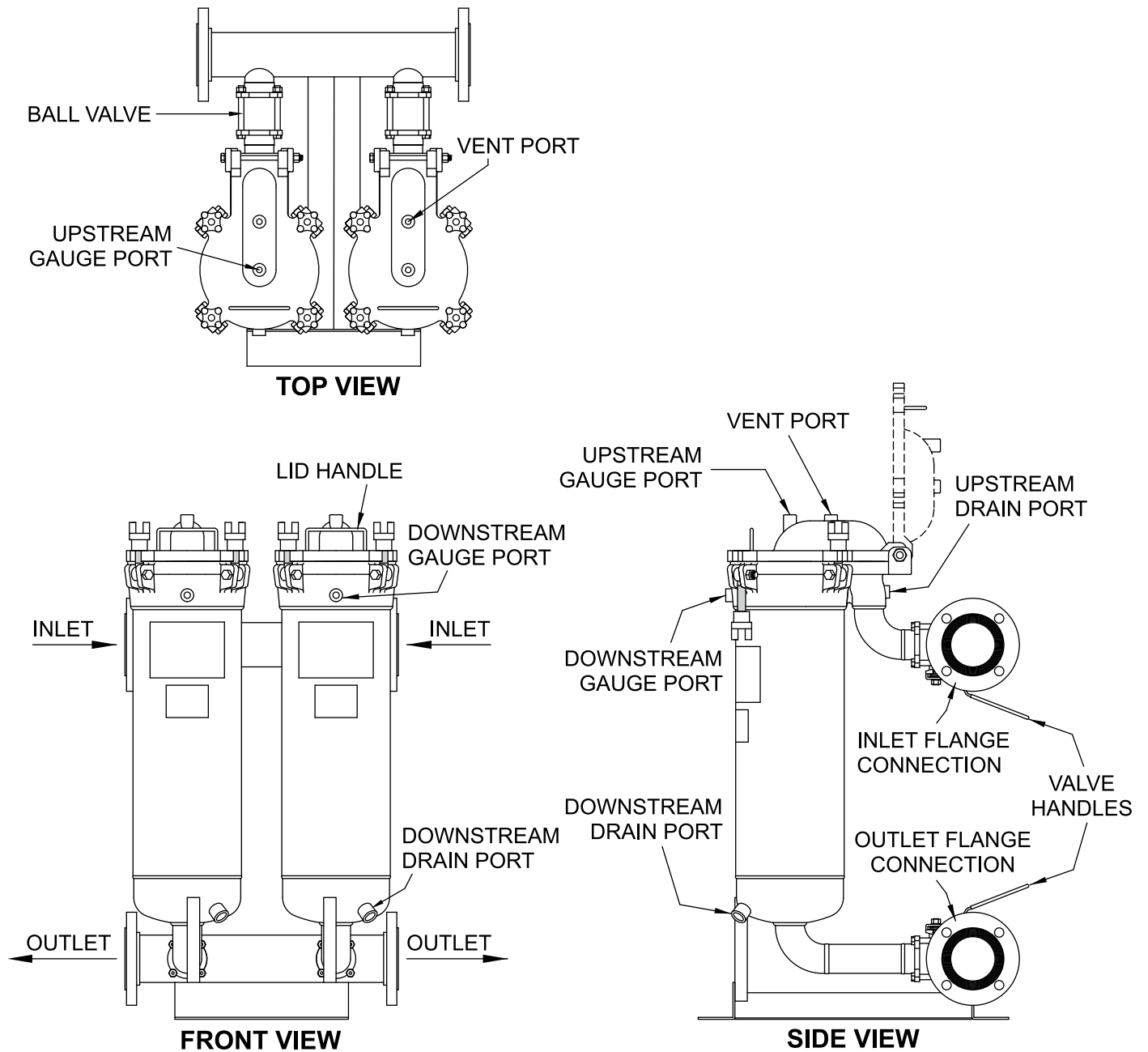

**Note: Refer to Product Brochure for specific type of connections and complete specifications.**

## SAFETY INFORMATION

Filtration Systems Filter Vessels are designed to filter liquids under pressure in accordance with the temperature and pressure restrictions stamped on the nameplate. The following procedures are mandatory for all users operating our Filter Vessels. Retain this manual, and any product related literature for review by all personnel operating or supervising the operation of this equipment.

**This manual contains safety information that is important to know and understand. To help recognize this information, observe the following symbols.**

 **DANGER** Danger indicates an imminently hazardous situation which, if not avoided, will result in death or serious injury.

 **WARNING** Warning indicates a potentially hazardous situation which, if not avoided, could result in death or serious injury.

 **CAUTION** Caution indicates a potentially hazardous situation which, if not avoided, could result in minor or moderate injury

 **NOTICE** Notice indicates important information, that if not followed may cause damage to equipment or property.

### Follow the Installation, Operating and Safety Instructions in this Manual.

**Improper use of Filter Vessels may result in injury or property damage. Any misuse or modification to our products will void both the manufacturer's warranty as well as the ASME certification of ASME Code Vessels. Safety information does not by itself eliminate any danger. Information or warnings are not a substitute for proper accident prevention measures.**

 **DANGER**

#### LETHAL SERVICE

**Filtration Systems Vessels are not designed for Lethal Service. "Lethal Service" refers to Vessels containing lethal substances, poisonous gases, or liquids of such a nature that a very small amount of the gas or vapor of the liquid (mixed or unmixed) is dangerous to life when inhaled. In addition, substances of this nature that are stored under pressure, or may generate pressure if stored in a closed Vessel, are considered lethal.**

 **WARNING**

**Wear personal protective equipment (PPE) including protective garments, splash protection, eye protection and respirators, as required.**

**Always check chemical and thermal compatibility of Housing Material, O-Rings, Gaskets, and Media with the fluid being filtered. Consult a liquid compatibility guide or ask your local dealer. Fluid compatibility includes all materials in contact with the liquid under elevated pressures and temperatures.**

**Before pressurizing a Filter Vessel, always make sure you have fastened the Lid Hardware.**

**O-Rings are subject to wear and should be checked each time the Filter Vessel is opened. Replace O-Rings prior to pressurization of the Filter Vessel. Be certain that the O-Ring material is both chemically and thermally compatible with the fluid being filtered.**

**Always relieve pressure to the system and stop the flow of liquid before loosening the Lid Hardware or opening the Vessel Lid.**

**In certain operating environments, static electrical charges or sparks may cause combustion or explosion of volatile materials. Properly ground equipment, as required.**

**Removing Filter Media from packaging may produce static electrical sparks. To avoid risk of combustion or explosion, never open static packaging in or around areas containing potentially flammable or explosive materials, liquids or gases.**

**Disposal of Filter Media: A Filter Bag or Cartridge that has been used with a hazardous liquid may contain residual amounts of this material and should be handled with the same safeguards that would be used in handling any hazardous and/or toxic material. It is the user's responsibility to dispose of all Filter Media in accordance with Federal, State, and/or Local laws or requirements.**



# INSTALLING THE FILTER HOUSING

## Unpacking the Equipment

- 1 Carefully remove the Housing from carton or pallet and check for damage.
- 2 Remove and save all product literature shipped inside the Housing or Support Basket.
- 3 Remove protective covers from flanged or sanitary connections.
- 4 Halar® Lined Housings and Vessels with Interior Polished Finishes are specially wrapped for additional protection. To prevent damage to the surface finish, use care when unpacking.
- 5 Confirm that the specifications and flow rate parameters have been checked against operating conditions. Housing flow rates, listed in product brochures, are based on water in a Housing without Filter Media. Actual flow rates are determined by the specific Filter Media, as well as the characteristics of the application.

Halar is a registered Trademark of Solvay



**Do not exceed maximum allowable Pressure or Temperature stamped on the nameplate of the Housing.**

## NOTICE

**Removal of the Nameplate voids the Product Warranty and eliminates future identification of the product. Welding to the Housing will void the Product Warranty and the Code Status of ASME Housings.**

## Individual Housings & Valved, Individual Housings

- 1 Anchor the Tripod Stand to the floor or stable base.
- 2 Loosen the bolts on the Tripod Stand and raise or lower the housing to accommodate piping requirements as necessary.

## Multi-Housing Systems

- 1 Multi-Housing Systems are equipped with two Inlet and two Outlet connections, located on the Inlet (top) and Outlet (bottom) headers. Select diagonally-opposed Inlet and Outlet points to accommodate space and/or piping requirements. The Inlet and Outlet are to be connected at the furthest point from one another. (NOT INLET OVER OUTLET).
- 2 Seal all unused connections with a (user-furnished) blind flange, threaded plug or cap of compatible materials.
- 3 Place the Frame on a secure, level surface.
- 4 If the unit is non-valved, a shut-off Valve should be installed before and after the Filter System, allowing the unit to be shut down during Media change-out. *Valved, modular filter systems allow individual Housings to be isolated for Media change-out so there is no disruption of service.*

## General Installation Notes

- Prepare the general area where the system will be installed. Do not pipe based on a drawing, but rather the actual equipment itself.
- Pre-pipe to the general area where the system will be installed, then connect FROM the Filter Housing to the piping. Do not force or bend the Housing out of line when piping.
- Clean the Filter Housing(s) before installation.
- The direction of liquid flow is from the Inlet (top) through the Outlet (bottom) of the Housing. Always pump through the Filter Housing. The discharge of the pump should feed the Inlet of the Housing.
- If there is a possibility of backflow to the Housing when the system is turned off, install an outlet valve to protect the filter media.
- Threaded Connections: We recommend the use of a thread sealant.
- Flanged or Sanitary Connections: Confirm that the gaskets used are compatible with the application.
- If anchoring is desired, drill bolt holes after piping connections are completed. Do not drill bolt holes based on dimensional drawings.
- Flush the system of any debris that may have resulted from installation prior to testing or first use.

**All Housings are Hydrostatically Tested (tested with water, under pressure) prior to shipment. Do not test with air or gas.**

- Vent Ports, Drain Ports and Gauge Ports are standard on all *Filtration Systems* Housings. Install auxiliary Valves and Gauges in the appropriate ports at this time:

A Vent Valve should be installed in the Vent Port on the Lid(s).

Pressure Gauges, used to monitor differential pressure, should be installed in the Gauge Ports on the Lid and the Filter Vessel Body of each Housing.

Drain Valves should be installed in the Drain Ports on the Bottom Head of the Housing and on the Body for the collection of residual liquid.

- Seal all unused Vent, Drain or Gauge Ports prior to start-up (user-furnished).
- Confirm that the O-Rings have been properly installed in the Lid or Body of each Housing.
- If the Housing or System is to be used with Filter Bags, install a Perforated Support Basket in each Housing. Follow instructions for INSTALLING FILTER MEDIA.
- If the Housing is to be used with a Lined Basket or Strainer Basket, install it with the appropriate sealing gasket.

### **WARNING**

**Always check chemical and thermal compatibility of Housing Material, O-Rings, Gaskets, Valves, Gauges, Flanges, Plugs and Filter Media with the fluid being filtered. Consult a liquid compatibility guide. Fluid compatibility includes all materials in contact with the liquid under elevated pressures and temperatures.**

## INSTALLING FILTER MEDIA

### NOTICE

Filtration occurs by capturing particles throughout the depth of the media. As a result, single-use filter media is disposable and cannot be washed or reused.

### WARNING

Removing Filter Media from packaging may produce static electrical sparks. To avoid risk of combustion or explosion, never open static packaging in or around areas containing potentially flammable or explosive materials, liquids or gases.

## Installing Filter Bags

### NOTICE

Improper Filter Bag installation can result in Filter Bag breakage.

To facilitate Filter Bag installation, a **Filter Bag Insert** (sold separately) will eliminate the need for technicians to reach into the Bag during installation.

- 1 Take the housing “off-line”** (follow the SHUT DOWN PROCEDURES in the OPERATING Section). After draining and venting the Housing, loosen the four Bar Knob Assemblies from the Lid, and lay them back through the slots provided. Open the Vessel Lid using the Lid Handle, and tilt it back completely to the Lid Stop. Remove the used Filter Bag (follow procedures for FILTER BAG REMOVAL).
- 2 Be certain that a Perforated Support Basket is in place.** The use of a Support Basket is mandatory with Filter Bags.
- 3 Select the appropriate Accufit® or Ultrafit® welded Liquid Filter Bag.** Check chemical and thermal compatibility of the Filter Media to be used in an application.
- 4 Remove the Filter Bag from the plastic packaging.** Removing Filter Media from packaging may produce static electrical sparks. To avoid risk of combustion or explosion, never open static packaging in or around areas containing potentially flammable or explosive materials, liquids or gases.
- 5 Insert the Filter Bag into the Support Basket.** The round bottom of the Filter Bag is designed to conform to the shape of the Support Basket. Be certain the Filter Bag is fully extended and supported by the Basket, completely and evenly. Push down on the Bag Collar so it sits flush with the top of the flanged lip of the Support Basket.

Note: By design, our Filter Bags are larger in diameter and longer than the Support Basket, promoting ‘blousing’ with the extra fabric. Therefore, under pressure in all directions the Filter Bag remains fully supported mechanically by the Basket during use.



## Installing Large Diameter, High-Capacity, Drop-In Cartridge Filter Elements

- 1 Select the appropriate APX® Cartridge Filter Element and Sealing Gasket.** Remove the Element from the plastic packaging.
- 2 If there is a Perforated Support Basket or specialty basket installed, remove it from the Filter Housing.**  
The drop-in design of the APX Element does not require the use of a Support Basket.
- 3 Insert the APX Element** by lowering it into the Filter Housing until the Element is supported by the counterbore of the housing.



# OPERATING PROCEDURES

## Lid Sealing Procedure

- 1 Confirm that the appropriate O-Rings and Filter Media have been installed properly.
- 2 Close the Lid of the Vessel using the Lid Handle, being careful not to drop it.
- 3 Bring the four Bar Knob Assemblies up into position. Hand-tighten bolts in a diagonal pattern, then torque to specification in the same manner. **To ensure a secure seal, we recommend 30-50 ft./lbs. of torque on the Bar Knob Assemblies.**

## Start Up Procedure

- 1 Open the Vent Valve.
- 2 Gradually fill the Vessel with liquid by opening the Inlet Valve slowly. As liquid enters the Vessel, air is allowed to escape through the Vent Valve to prevent an air pocket from forming.
- 3 At the first sign of liquid immerging through the Vent Valve, immediately close the Vent Valve and open the Outlet Valve, allowing liquid to flow through the Filter Housing. This begins the filtration process.
- 4 Monitor the Upstream and Downstream pressure with Gauges, when the Filter Vessel is “on-line”. The difference between the two readings is known as the “pressure differential”, measured across the Filter Bag. Increased upstream pressure indicates “blinding”, and the need for Filter Bag replacement. Follow the Filter Bag manufacturer’s recommendation for maximum allowable differential pressure.

## Shut Down Procedure

- 1 Stop the flow of liquid to the Vessel by closing the Inlet Valve.
- 2 Close the Outlet Valve to isolate the Housing from the liquid flow.
- 3 Observe the pressure and temperature closely.

### **WARNING**

**Proceed to Step 4 only if the parameters are within safe limits.**

**Safeguards should be taken to wear personal protective equipment (PPE) suitable for the material being handled.**

- 4 The Vessel is still in a pressurized state. Slowly open the Downstream Drain Valve located at the bottom of the Filter Vessel, and capture the liquid in an appropriate container (i.e. suitable for the filtered material that you are evacuating).
- 5 Open the Vent Valve located on the top of the Filter Vessel Lid. This will promote faster gravity drainage when used in conjunction with the Downstream Drain Valve.
- 6 Open the upstream Drain Valve located on the Body. If there is any unfiltered residual liquid, collect it in a suitable container.
- 7 Loosen the four Bar Knob Assemblies from the Lid, and lay them back through the slots provided. Open the Vessel Lid using the Lid Handle, and tilt it back completely to the Lid Stop. The Media may now be removed for replacement (follow procedures for FILTER MEDIA REMOVAL).

## FILTER MEDIA REMOVAL

### WARNING

Wear personal protective equipment (PPE) suitable for the material being handled.

### NOTICE

Filter Media must be changed at or before the maximum differential pressure, recommended by the manufacturer. If the Filter Media is not changed on a timely basis, it will become “blinded” and will not drain.

Filtration occurs by capturing particles throughout the depth of the media. As a result, single-use filter media is disposable and cannot be washed or reused.

### Filter Bag Removal

- 1 Be certain the liquid has been drained from the Housing and Filter Bag (see SHUT DOWN PROCEDURES).
- 2 Grasp the Filter Bag Handles and pull the Collar inward to loosen the upper section of the Bag. Twist the Collar in a circular motion to release the cloth that may be embedded in the perforations of the Support Basket.
- 3 Anchor the Support Basket Flange while pulling the Filter Bag out of the Basket. If the Bag does not come loose easily, twist the Collar in a circular motion when pulling up.

### Large Diameter, Drop-In Cartridge Filter Element Removal

- 1 Be certain the liquid has been drained from the Housing and Cartridge Element (see SHUT DOWN PROCEDURES).
- 2 When a Drop-In Cartridge Element is fully loaded, debris will accumulate within the Element, eliminating the need to clean the Housing during change-out.
- 3 Remove the Cartridge Element from the Housing by grasping the built-in Handle and pulling it up and out of the Filter Housing.

### WARNING

**Disposal of Filter Media: A Filter Bag or Cartridge that has been used with a hazardous liquid may contain residual amounts of this material and should be handled with the same safeguards that would be used in handling any hazardous and/or toxic material. It is the user’s responsibility to dispose of all Filter Media in accordance with Federal, State, and/or Local laws or requirements.**

## MAINTAINING YOUR FILTER HOUSING

### O-Rings

“O-Rings” are subject to wear and should be checked for dirt, cuts, or swelling each time the Filter Vessel is opened. Replacement of O-Rings should be done prior to pressurization of the Filter Vessel. Be certain that the O-Ring material is both chemically and thermally compatible with the fluid being filtered (see page 20 for replacement O-Rings).

### Lid Hardware

Lid Sealing Hardware should be checked each time the Filter Vessel is opened. Inspect the Eyebolts for elongation or thread wear, due to excessive tightening. Check all components of the Bar Knob Assembly for corrosion and replace if necessary (see page 15 for replacement Hardware).

### Ball Valve Maintenance

*Filtration Systems* Valved Housings are constructed with S/S, Three-Piece, Full-Port Ball Valves, with Teflon Seals and Gaskets. Periodically flush the system to prevent build-up of particulate in the body of the Valve.

Replace worn Seals when necessary (see page 19 for replacement Valves & Seals).



**Changing Hardware or Ball Valves may produce sparks. Properly ground equipment as required.**

## TROUBLESHOOTING

### Housing Leaks

All *Filtration Systems* Vessels are hydrostatically tested at our factory to assure the integrity of the Housing. If a Housing leaks:

- Confirm that the O-Rings are in place, and properly installed. Check O-Rings for dirt, cuts or swelling and replace, if necessary.
- Check the Lid Sealing Procedure; apply the recommended torque pressure and reseal the Housing.
- Make sure that both the Inlet and Outlet Shut-Off Valves are open for filtering.
- Check all threaded connections; use a threading compound product, as required.
- Check plumbing connections.
- Check the Housing Body to determine if it was bent out of line during installation. Apply a straight edge over the machined face of the Housing Body from front to back. The straight edge should sit flush on the Body, without gaps.

### Ball Valves

- If the Ball Valve is leaking, identify the leak origin and replace the Seals and Packing.
- If the Valve is difficult to open and close, remove the Valve Body and check for obstructions inside the Valve. After removing any debris, reinstall the body of the Valve.
- Check the Valve Handle for straightness. Our Valves have built-in ‘Stops’. If the Handle is bent it will give a false ‘Stop’ position. The Valve may appear closed, when it remains slightly open. If this occurs, replace the Valve Handle.
- If the Valves don’t fully open or close, the ‘Stop’ or the Handle Slot engaging the Valve Stem may be misshapen, due to excessive force. Remove the Valve Handle and check the ‘Stop’ and the Machined Slot for distortion. If either is distorted replace the Handle.

### Surface Stains

Stains may occur on stainless steel Housing surfaces, due to either process or atmospheric conditions.

If surface staining occurs, it can be easily removed with a clean stainless steel wire brush or an aluminum oxide grinding wheel.

## Abnormally Short Filter Bag Life

- Check the position of the Filter Bag in the Support Basket. Be certain that the Filter Bag is fully extended and supported by the Basket.
- Check if the Filter Bag has been ripped or torn.
- Excessive flow rates may require the user to increase the number of Filter Bags and Filter Housings operating in parallel. As a general rule, adding a second Filter running in parallel will give you three times the Filter Bag life as a single filter. Reducing the flow rate to a Housing will allow increased loading capacity and promotes longer Filter Bag life.

### WARNING

**Always check chemical and thermal compatibility of Housing Material, O-Rings, Gaskets, Valves, Gauges, Flanges, Plugs, and Filter Media with the fluid being filtered. Consult a liquid compatibility guide. Fluid compatibility includes all materials in contact with the liquid under elevated pressures and temperatures.**

## Bag Breakage

### Possible causes of Bag breakage:

**Excessive flow rates or differential pressure**

**Chemical or thermal incompatibility with the Filter Bag**

**Improper Filter Bag installation (i.e. Bag not fully extended in the Basket) Bag floating due to backflow in the system**

**Installation of the Bag before the Housing is fully drained**

**Installation of the Bag without a Support Basket**

- Check for process changes or changes in the liquid being filtered.
- Check chemical and thermal compatibility.
- Check proper Filter Bag installation procedures (see INSTALLING FILTER MEDIA).
- Check to see if the Filter Bag is dirty and “blinded”.
- Do not exceed the Manufacturer’s recommended maximum temperature or flow rate parameters.
- Do not exceed the Manufacturer’s recommendations for maximum allowable differential pressure.
- Be certain that Gauges are accurate and in proper working order.

### NOTICE

#### PARTICLE CHARACTERIZATION ANALYSIS

***Filtration Systems* offers Particle Characterization Studies of liquid samples. Particle Analysis provides meaningful data, useful in specifically identifying filtration requirements for the selection of equipment and Filter Media.**

**Please contact Technical Services Department for details.**

## REPLACEMENT LID SEALING HARDWARE

Replacement hardware is available in stainless or carbon steel for *Filtration Systems* ASME Code and Industrial Grade vessels. *Filtration Systems Over-The-Top* vessels utilize four swing-bolt assemblies to secure the lid. A hardware assembly consists of four component parts: bar knob, eyebolt, axle bolt, and axle nut.



## AUXILIARY VALVES

All *Filtration Systems* housings feature a vent port in the lid and a drain port at the base of the filter for installation of auxiliary valves. Vent valves may be installed at the top of the lid to remove air pockets from process fluid lines and promote faster gravity drainage, when used in conjunction with the inlet and outlet drain valves.

The outlet drain valve allows the collection of filtered liquid after the vessel is taken off-line. During operation, this valve may also be used for sampling filtered liquid. The upstream drain port and valve on our housings, allows sampling of pre-filtered liquid. Ball valves are available in stainless steel or brass, and are supplied with stainless steel nipples.

*Filtration Systems* housings are equipped with the following threaded ports:

**Vent Port:** 1/4" NPT (all housings)

**Upstream Drain Port:** 1/4" NPT (all housings)

**Downstream Drain Port:** 3/4" NPT (#1 & 2 size)  
1/2" NPT (#4 & 5 size)

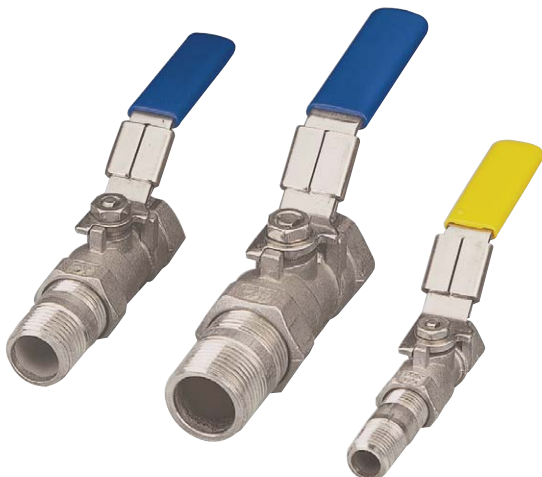

## BAR KNOB WRENCH

Although no special tools are required to seal our housings, a Bar Knob Wrench is an ideal accessory. This convenient device allows operators to quickly torque or loosen the lid closure nuts (bar knobs) of a filter vessel. This ratchet wrench is fabricated of plated carbon steel and may be used on all *Filtration Systems* housings.



## PRESSURE GAUGES

All *Filtration Systems* housings feature two gauge ports (1/4" NPT) to allow users to monitor both the upstream and downstream pressure. The variance between the two readings is called the *differential pressure*, and is used to determine when a filter bag is "blinding," requiring change-out. Gauges have a 2-1/2" dial, 1/4" NPT connections and are back-center mounted.

**They are available in three ranges:**

0-100 psi, 0-160 psi and 0-300 psi.

All gauges have a stainless steel case, and may be ordered with either brass or stainless internals.

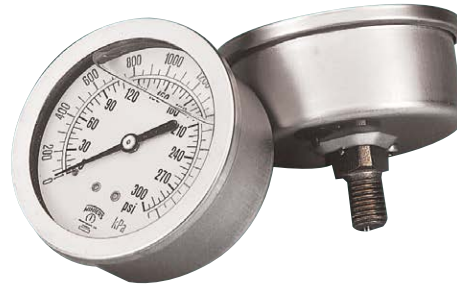

## ADJUSTABLE TRIPOD STANDS

Allows the user to raise and lower the Filter Vessel, as required.





REPLACEMENT LID SEALING HARDWARE	
MODEL	DESCRIPTION
H-RS-150 *	Bar Knob Assembly for S/S, ASME Housings - 150 psi
H-RS-150-S/S	S/S Bar Knob Assembly for S/S, ASME Housings - 150 psi
H-RS-300 *	Bar Knob Assembly for S/S, ASME Housings - 300 psi
H-RS-300-S/S	S/S Bar Knob Assembly for S/S, ASME Housings - 300 psi
H-RC-150 *	Bar Knob Assembly for C/S, ASME Housings - 150 psi
H-RC-300 *	Bar Knob Assembly for C/S, ASME Housings - 300 psi
H-RNS *	Bar Knob Assembly for S/S, Industrial Grade Housings
H-RNS-S/S	S/S Bar Knob Assembly for S/S, Industrial Grade Housings
H-RNC *	Bar Knob Assembly for C/S, Industrial Grade Housings
H-RNS-141/151 *	Bar Knob Assembly for S/S, Miniature Housings (4" Diameter)
H-RNC-141/151 *	Bar Knob Assembly for C/S, Miniature Housings (4" Diameter)
H-RNS-141/151-S/S	S/S Bar Knob Assembly for S/S Miniature Housings
BARKNOBWRENCH	Bar Knob Wrench (for use with all housings) Quickly torques or loosens lid closure hardware

PRESSURE GAUGES, DRAIN VALVES AND VENT VALVES	
MODEL	DESCRIPTION
H- S/S-GVP-8	S/S, Gauge/Valve Package for 8" diameter Housings
H- BRASS-GVP-8	Brass Gauge/Valve Package for 8" diameter Housings
H- S/S-GVP-4	S/S, Gauge/Valve Package for 4" diameter Housings
H- BRASS-GVP- 4	Brass, Gauge/Valve Package for 4" diameter Housings
H-S/S GAUGE-100	1/4" NPT S/S, 0-100 psi range
H-S/S GAUGE-160	1/4" NPT S/S, 0-160 psi range
H-S/S GAUGE-300	1/4" NPT S/S, 0-300 psi range
H-S/B GAUGE-100	1/4" NPT S/S & Brass, 0-100 psi range
H-S/B GAUGE-160	1/4" NPT S/S & Brass, 0-160 psi range
H-S/B GAUGE-300	1/4" NPT S/S & Brass, 0-300 psi range
H-1/4 S/S VALVE	1/4" T-316 S/S Ball Valve with Threaded Nipple
H-1/2 S/S VALVE	1/2" T-316 S/S Ball Valve with Threaded Nipple
H-3/4 S/S VALVE	3/4" T-316 S/S Ball Valve with Threaded Nipple
H-1/4 BRASS VALVE	1/4" Brass Ball Valve with Threaded Nipple
H-1/2 BRASS VALVE	1/2" Brass Ball Valve with Threaded Nipple
H-3/4 BRASS VALVE	3/4" Brass Ball Valve with Threaded Nipple

ADJUSTABLE TRIPOD STANDS	
MODEL	DESCRIPTION
H-S/STAND	S/S, Adjustable Tripod Stand, for 8" diameter Housings
H-C/STAND	Carbon, Adjustable Tripod Stand, for 8" diameter Housings

## Replacement Hardware

Replacement hardware is available in Plated Carbon Steel or Stainless Steel (S/S) for *Filtration Systems* ASME Code and Industrial Grade vessels.

*Filtration Systems Over-The-Top* vessels utilize four swing bolt assemblies to secure the lid. Each hardware assembly consists of the following component parts:

**Bar Knob** (Castle Nut)

**Eyebolt** (Swing Bolt)

**Axle Bolt**

**Axle Nut**

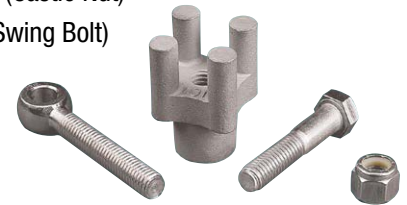

Component parts are not sold separately.

\* SA-193-B7 rod end Eyebolt, Zinc Plated Carbon Steel.

## Gauge/Valve Package

Fully equips auxiliary ports on *Filtration Systems* Housings. Package consists of:

- (2) Pressure Gauges (Upstream & Downstream)
- (2) Drain Valves (Upstream & Downstream)
- (1) Vent Valve

## Pressure Gauges

T-304 S/S Case, T-316 S/S Internals, 2 1/4" Dial, 1/4" NPT Back Center Connection.

T-304 S/S Case, Brass Internals, 2 1/4" Dial, 1/4" NPT Back Center Connection.

## Auxiliary Valves

All *Filtration Systems* Housings feature a Vent Port in the Lid, a Drain Port at the base of the Filter and an Upstream Drain Port.

**Vent Port:** 1/4" NPT (all housings)

**Drain Port:** 3/4" NPT (#1 & #2 Size),  
1/2" NPT (#4 & #5 Size)

**Upstream Drain Port:** 1/4" NPT (all housings)

## Adjustable Tripod Stands

For *Filtration Systems* #1 & #2 Size Individual Filter Vessels (112 & 122).

## PERFORATED SUPPORT BASKETS

Stainless Steel support baskets accommodate filter bag sizes #1, 2, 4 and 5.

*Filtration Systems'* Support Baskets have a perforated wall, and a solid, hemispherical bottom to fully support our filter bags. This patented design promotes "lateral fluid dispersion", resulting in increased solids loading capacity, and greater differential pressure capability of the filter bags.

Staggered pattern, perforated holes (9/64" diameter) maximize the usable surface area of any filter bag and provide greater basket strength than straight-line pattern perforations. Basket bottom has drainage holes and walls have a longitudinal taper to assist with filter bag removal.

Perforated Support Baskets are available in T-316 or T-304 Stainless Steel and are offered in size #1, 2, 4 and 5. Support baskets are required when using liquid filter bags.



## PERFORATED STRAINER BASKETS

Heavy-duty Perforated Strainer baskets convert size #1, 2, 4, and 5 filter vessels into high-capacity liquid strainers. When our filter housings are used with strainer baskets they allow heavy dirt loading at high flow rates. Perforated strainers are reusable and may be pressure cleaned, if required.

To maximize the usable surface area of the strainer basket, holes are punched in a staggered pattern. Constructed of T-304 stainless steel, strainers have a lift-out handle and a solid, flat bottom. Strainer Baskets are available with the following perforations:

**1/2" 3/8" 1/4" 3/16" 9/64" 3/32" 1/16" 3/64"**  
 (.500) (.375) (.250) (.1875) (.1406) (.0938) (.0625) (.0469)

## TRIPLE-WALL, MESH AND MICRON LINED BASKETS

These reusable baskets provide liquid straining and filtering at various levels of mesh and micron ratings. The lining specified is embedded between two perforated structural walls, allowing sustained pressure in both directions, and protecting it from harsh brushing or hose spray while cleaning. Fully welded construction assures that no particle bypass occurs around the welded seams. Ideally suited for high temperature applications and/or aggressive service, baskets are constructed of Stainless Steel and include a Buna sealing gasket.

**Mesh:** 20, 30, 40, 50, 60, 70, 80, 100, 150, 200 Industrial Service

**Micron:** 40, 90, 160, 250 Industrial Service  
 5, 10, 15, 25 Light-Duty, Specialty Use



## SUPPORT BASKETS AND ACCESSORY BASKETS FOR 8" DIAMETER FILTER VESSELS (MODELS 112 & 122)

MODEL	DESCRIPTION	
<b>A-#1PB-316</b>	#1 Size Perforated Support Basket, T-316 S/S	9/64" diameter holes, staggered pattern wall; hemispherical bottom
<b>A-#1PB-304</b>	#1 Size Perforated Support Basket, T-304 S/S	
<b>A-#2PB-316</b>	#2 Size Perforated Support Basket, T-316 S/S	
<b>A-#2PB-304</b>	#2 Size Perforated Support Basket, T-304 S/S	
<b>A-#1PB-SANITARY</b>	#1 Size, Sanitary Design, Electropolish, Perforated Support Basket, T-316 S/S *	
<b>A-#2PB-SANITARY</b>	#2 Size, Sanitary Design, Electropolish, Perforated Support Basket, T-316 S/S *	
<b>A-#1PERF-MLB-TW</b>	#1 Size Triple-Wall, Mesh or Micron Lined Basket, T-316 S/S *	<b>Mesh or Micron Choices:</b> <b>Mesh:</b> 20, 30, 40, 50, 60, 70, 80, 100, 150, 200 (Industrial Service) <b>Micron:</b> 40, 90, 160, 250 (Industrial Service)
<b>A-#2PERF-MLB-TW</b>	#2 Size Triple-Wall, Mesh or Micron Lined Basket, T-316 S/S *	
<b>A-#1SMLB-TW</b>	#1 Size, Triple-Wall, Small Micron Lined Basket, T-316 S/S *	<b>Micron Choices:</b> 5, 10, 15, 25 (Light Duty, Specialty Use)
<b>A-#2SMLB-TW</b>	#2 Size, Triple-Wall, Small Micron Lined Basket, T-316 S/S *	
<b>A-#1STRAINER</b>	#1 Size, Heavy Duty Perforated Strainer Basket, T-304 S/S *	<b>Hole Size:</b> 1/2" 3/8" 1/4" 3/16" 9/64" 3/32" 1/16" 3/64" <b>Decimal:</b> (.500) (.375) (.250) (.1875) (.1406) (.0938) (.0625) (.0469)
<b>A-#2STRAINER</b>	#2 Size, Heavy Duty Perforated Strainer Basket, T-304 S/S *	
<b>A-#1PREFILTER</b>	#1 Size Pre-Filter, T-316 S/S- Micron Lined	<b>Micron Choices:</b> 90, 160 or 250
<b>A-#2PREFILTER</b>	#2 Size Pre-Filter, T-316 S/S- Micron Lined	
<b>A-#1RESTRAINER</b>	#1 Size Filter Bag Restrainer, T-316 S/S	Keeps filter bag properly seated during filtration
<b>A-#2RESTRAINER</b>	#2 Size Filter Bag Restrainer, T-316 S/S	
<b>A-#1MB</b>	#1 Size Mesh Basket, T-316 S/S	8 x 8 mesh; cone-shaped bottom
<b>A-#2MB</b>	#2 Size Mesh Basket, T-316 S/S	
<b>A-#1CB</b>	#1 Size Canister Basket, T-316 S/S	Holds granular materials, such as activated carbon. Solid wall; perforated, hemispherical bottom
<b>A-#2CB</b>	#2 Size Canister Basket, T-316 S/S	
<b>A-BAG INSERT</b>	#1 or #2 Size Filter Bag Insert, T-316 S/S (112 or 122)	Allows for easy installation of filter bags
<b>A-#1DISPLACER</b>	#1 Size, Liquid Displacer, T-316 Stainless Steel	
<b>A-#2DISPLACER</b>	#2 Size, Liquid Displacer, T-316 Stainless Steel	

\* Includes Buna-Gasket Seal



## STANDS, BRACKETS & ACCESSORIES FOR MINIATURE HOUSINGS 4" DIAMETER FILTER VESSELS (MODELS 141 & 151)

MODEL	DESCRIPTION	
<b>H-S/STAND-141</b>	Stainless Steel Stand for NS-141	
<b>H-C/STAND-141</b>	Carbon Steel Stand for NC-141	
<b>H-S/STAND-151</b>	Stainless Steel Stand for NS-151	
<b>H-C/STAND-151</b>	Carbon Steel Stand for NC-151	
<b>H-S/BRACKET</b>	Stainless Steel Bracket for Miniature Housings ( <b>141</b> or <b>151</b> )	
<b>H-C/BRACKET</b>	Carbon Steel Bracket for Miniature Housings ( <b>141</b> or <b>151</b> )	
<b>A-#4PB</b>	#4 Size Perforated Support Basket, T-316 S/S	9/64" diameter holes, staggered pattern wall; hemispherical bottom
<b>A-#5PB</b>	#5 Size Perforated Support Basket, T-316 S/S	
<b>A-#4CB</b>	#4 Size Canister Basket with Liquid Diffuser	Holds granular materials, such as activated carbon Solid wall; perforated, hemispherical bottom
<b>A-#5CB</b>	#5 Size Canister Basket with Liquid Diffuser	
<b>A-#4PERF-MLB</b>	#4 Size Mesh or Micron Lined Basket, T-316 S/S *	<b>Mesh or Micron Choices:</b> <b>Mesh:</b> 20, 30, 40, 50, 60, 70, 80, 100, 150, 200 (Industrial Service) <b>Micron:</b> 5, 10, 15, 25 (Light Duty, Specialty Use) <b>Micron:</b> 40, 90, 160, 250 (Industrial Service)
<b>A-#5PERF-MLB</b>	#5 Size Mesh or Micron Lined Basket, T-316 S/S *	
<b>A-#4STRAINER</b>	#4 Heavy Duty Perforated Strainer Basket, T-304 S/S *	<b>Hole Size:</b> 1/2" 3/8" 1/4" 3/16" 9/64" 3/32" 1/16" 3/64" <b>Decimal:</b> (.500) (.375) (.250) (.1875) (.1406) (.0938) (.0625) (.0469)
<b>A-#5STRAINER</b>	#5 Heavy Duty Perforated Strainer Basket, T-304 S/S *	
<b>A-#4/5 BAGINSERT</b>	#4 or #5 Size Filter Bag Insert, T-316 S/S	Allows for easy installation of filter bags
<b>A-#4CC</b>	#4 Cartridge Chamber, T-316 S/S (Holds One 10" Cartridge Filter)	
<b>A-#5CC</b>	#5 Cartridge Chamber, T-316 S/S (Holds One 20" Cartridge Filter)	
<b>O-CC-GASKET-B4</b>	Buna Gasket for Miniature Housing Cartridge Chambers ( <b>141</b> or <b>151</b> )	
<b>O-CC-GASKET-T4</b>	Teflon® Gasket for Miniature Housing Cartridge Chambers ( <b>141</b> or <b>151</b> )	

\* Includes Buna-Gasket Seal



## REPLACEMENT INLET/OUTLET BALL VALVES & PARTS

MODEL	DESCRIPTION
<b>BALLVALVE- 2"</b>	2" Ball Valve, T-316 S/S, 3 piece, Full-Port with Teflon Seats & Gaskets
<b>BALLVALVE- 1-1/4"</b>	1-1/4" Ball Valve, T-316 S/S, 3 piece, Full-Port with Teflon Seats & Gaskets
<b>REPAIR KIT- 2"</b>	Replacement Teflon Seats & Gaskets for <i>Filtration Systems</i> 2" Ball Valve
<b>REPAIR KIT- 1-1/4"</b>	Replacement Teflon Seats & Gaskets for <i>Filtration Systems</i> 1-1/4" Ball Valve
<b>VALVE HANDLE</b>	Replacement Valve Handle for <i>Filtration Systems</i> Ball Valves
<b>VALVE-LOCKOUT</b>	Ball Valve Safety Lockout assembly, 2 per set

## Ball Valves

*Filtration Systems* Valved Filter Systems have two Stainless Steel Ball Valves installed on the Inlet and Outlet of each vessel allowing individual housings to be isolated for Media change-out.



**Ball Valve with Safety Lockout Assembly**

## REPLACEMENT HOUSING LIDS

MODEL	DESCRIPTION
<b>S-LID</b>	Stainless Steel Replacement Lid for <i>Filtration Systems</i> ASME Code, 8" Diameter Housings, T-316 S/S; Hinge Pin Included
<b>C-LID</b>	Carbon Steel Replacement Lid for <i>Filtration Systems</i> ASME Code, 8" Diameter Housings; Hinge Pin included
<b>NS-LID</b>	Stainless Steel Replacement Lid for <i>Filtration Systems</i> Industrial Grade, 8" Diameter Housings, T-304 S/S; Hinge Pin included
<b>NC-LID</b>	Carbon Steel Replacement Lid for <i>Filtration Systems</i> Industrial Grade, 8" Diameter Housings; Hinge Pin included
<b>NS-LID 4</b>	Stainless Steel Replacement Lid for <i>Filtration Systems</i> Industrial Grade, 4" Diameter Housings, T-316 S/S; Hinge Pin included
<b>NC-LID 4</b>	Carbon Steel Replacement Lid for <i>Filtration Systems</i> Industrial Grade, 4" Diameter Housings; Hinge Pin included

## Housing Lids

To order a replacement Lid, please have the following information available (found on the Housing Nameplate):

- Serial Number
- Maximum Pressure Rating
- Maximum Temperature
- Rating Year of Manufacture

Note: Lid Sealing Hardware and O-Rings are sold separately.

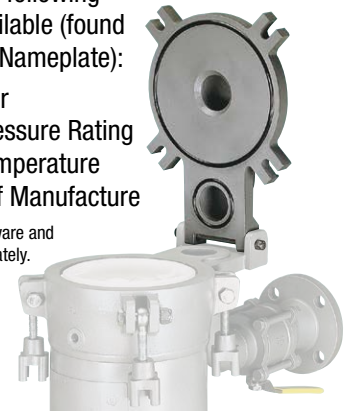

## CARTRIDGE CHAMBERS & CHAMBER HARDWARE FOR 8" DIAMETER FILTER VESSELS (MODELS 112, 122 & 130)

MODEL	DESCRIPTION
<b>A-10CC</b>	10" Cartridge Chamber & Hardware, T-316S/S *
<b>A-20CC</b>	20" Cartridge Chamber & Hardware, T-316S/S *
<b>A-30CC</b>	30" Cartridge Chamber & Hardware, T-316S/S *
<b>Replacement Hardware</b>	
<b>H-GUIDEPOST1</b>	10" Guide Post, T-316 S/S **
<b>H-GUIDEPOST2</b>	20" Guide Post, T-316 S/S **
<b>H-GUIDEPOST3</b>	30" Guide Post, T-316 S/S **
<b>H-BTMSEATCAP</b>	Bottom Pedestal Seat **
<b>H-SPRINGASSBLY</b>	Spring Assembly, Top Seat Cap & Spring **
<b>O-BUNA-GASKET</b>	Buna-N Sealing Gasket (Standard)
<b>O-EPR-GASKET</b>	Ethylene Propylene/EPDM Sealing Gasket
<b>O-NEO-GASKET</b>	Neoprene/Chloroprene Sealing Gasket
<b>O-SIL-GASKET</b>	Silicone Sealing Gasket
<b>O-VITON-GASKET</b>	Viton® Sealing Gasket
<b>O-AFLAS-GASKET</b>	Aflas Sealing Gasket
<b>O-TEF-GASKET</b>	Teflon® Sealing Gasket

## Cartridge Chambers

Insertion of the Chamber into any of our Filter Bag Housings converts the Vessel into a cartridge Housing, without modification of piping or change of liquid flow path. These removable, positive sealing Chambers hold four standard Cartridge Filters in a "Cluster of Four" arrangement.

Cartridge Chambers are available in three sizes to hold standard 10", 20", and 30" length Cartridge Filters.

Use one 20" Chamber for all Model **122** Housings, one 10" Chamber for all Model **112** Housings, or one 30" Chamber for all Model **130** Housings.



\* Includes Buna-Gasket Seal  
\*\* (4) required for each Cartridge Chamber

## O-RINGS AND GASKETS

MODEL	DESCRIPTION
<b>Lid O-Rings for <i>Filtration Systems</i> 8" Diameter Filter Vessels (112, 122, 110, 120, 130)</b>	
<b>O-BUNA</b>	Buna-N O-Rings, 2 per set (standard)
<b>O-EPR</b>	Ethylene Propylene/EPDM O-Rings, 2 per set
<b>O-NEOPRENE</b>	<i>Neoprene</i> /Chloroprene O-Rings, 2 per set
<b>O-SILICONE</b>	Silicone O-Rings, 2 per set
<b>O-VITON</b>	<i>Viton</i> O-Rings, 2 per set
<b>O-AFLAS</b>	<i>Aflas</i> O-Rings, 2 per set
<b>O-TEFLON</b>	<i>Teflon</i> O-Rings (Solid White), 2 per set
<b>O-FEP/SILICONE</b>	FEP Encapsulated/Silicone O-Rings, 2 per set
<b>O-FEP/VITON</b>	FEP Encapsulated/ <i>Viton</i> O-Rings, 2 per set
<b>Lid O-Rings for <i>Filtration Systems</i> 4" Diameter Filter Vessels (141 or 151)</b>	
<b>O-BUNA 141/151</b>	Buna-N O-Rings for Miniature Vessels, 2 per set (standard)
<b>O-EPR 141/151</b>	Ethylene Propylene/EPDM O-Rings for Miniature Vessels, 2 per set
<b>O-NEOP 141/151</b>	<i>Neoprene</i> /Chloroprene O-Rings for Miniature Vessels, 2 per set
<b>O-SIL 141/151</b>	Silicone O-Rings for Miniature Vessels, 2 per set
<b>O-VIT 141/151</b>	<i>Viton</i> O-Rings for Miniature Vessels, 2 per set
<b>O-TEF 141/151</b>	<i>Teflon</i> O-Rings (Solid White) for Miniature Vessels, 2 per set
<b>O-F/S 141/151</b>	FEP Encapsulated/Silicone O-Rings for Miniature Vessels, 2 per set
<b>O-F/V 141/151</b>	FEP Encapsulated/ <i>Viton</i> O-Rings for Miniature Vessels, 2 per set
<b>Basket Flange Sealing Gasket for <i>Filtration Systems</i> #1 &amp; #2 Size Specialty Baskets (112 or 122) (Strainer Baskets &amp; Mesh/ Micron Lined Baskets)</b>	
<b>O-BUNA-GASKET</b>	Buna-N Sealing Gasket (standard)
<b>O-EPR-GASKET</b>	Ethylene Propylene/EPDM Sealing Gasket
<b>O-NEO-GASKET</b>	<i>Neoprene</i> /Chloroprene Sealing Gasket
<b>O-SIL-GASKET</b>	Silicone Sealing Gasket
<b>O-VITON-GASKET</b>	<i>Viton</i> Sealing Gasket
<b>O-AFLAS-GASKET</b>	<i>Aflas</i> Sealing Gasket
<b>Basket Flange Sealing Gasket for <i>Filtration Systems</i> #4 &amp; #5 Size Specialty Baskets (141 or 151) (Strainer Baskets &amp; Mesh/ Micron Lined Baskets)</b>	
<b>O-BUNA-GASKET-4</b>	Buna-N Sealing Gasket (standard) for 141/151 Basket Flange
<b>O-TEF-GASKET-4</b>	<i>Teflon</i> Sealing Gasket for 141/151 Basket Flange



**⚠ WARNING**

Always check chemical and thermal compatibility of Housing Material, O-Rings, Gaskets, Valves, Gauges, Flanges, Plugs and Filter Media with the fluid being filtered. Consult a liquid compatibility guide. Fluid compatibility includes all materials in contact with the liquid under elevated pressures and temperatures.

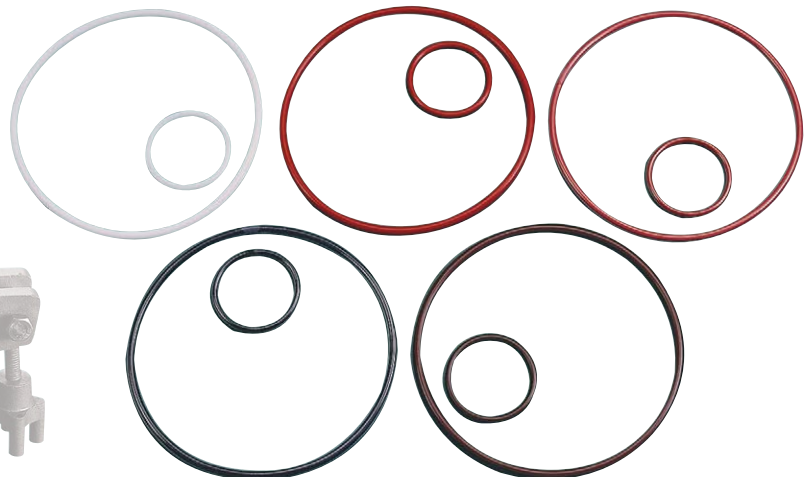

## ACCUFIT® WELDED EXPANDED MEDIA FILTER BAGS

A unique filter product, designed for demanding, high purity liquid filtration applications has been developed offering superb flow, robust solids loading, minimal differential pressure and precise micron retention—all essential requirements for maximizing results...

Specifically manufactured for high solids loading and strength; excellent for high purity chemical and water, pharmaceutical, food, edible or high purity synthetic oils, bio-fuels and cosmetic use; superb quality filtering incorporates convenience, cleanliness and productivity. These filters are available in quad, six, eight, ten-wall, or more laminated plies, are non-fiber shedding and can handle elevated temperatures (in 100% Nylon or Polypropylene). Graded-density and/or redundant layers of FDA compliant monofilament are ultrasonically laminated and formed, and use a non-bypassing sealing collar with removal handles. *Accufit* Welded Expanded Media is designed in accordance with the ISO 4406:1999 standard.

The filter media loads on the surface of the filter, trapping particles in its many tortuous grid paths. Useful for high-flow and strength, without significant increased differential pressure imposed from the filter. It is the opposite of a depth filter—one that loads particulate on the surface of the filtering layers—not in them. As such, when finished, it will hold large amounts of solids—and still drain liquid, as it is highly porous. One of the unique features of this filter is that it may be “tweaked” as necessary to accommodate a wide array of liquid filtering conditions—e.g. greater throughput, tighter micron retention, etc. . .

### Available Sizes:

- P2 Size** = 7" Dia. x 32" Long
- P4 Size** = 4" Dia. x 14" Long
- P1 Size** = 7" Dia. x 16" Long
- P5 Size** = 4" Dia. x 24" Long

Order in multiples of 50 pieces (minimum).  
Please order carefully, as filter bags are not returnable.

## EXPANDED MEDIA MODEL NUMBER CODING SYSTEM

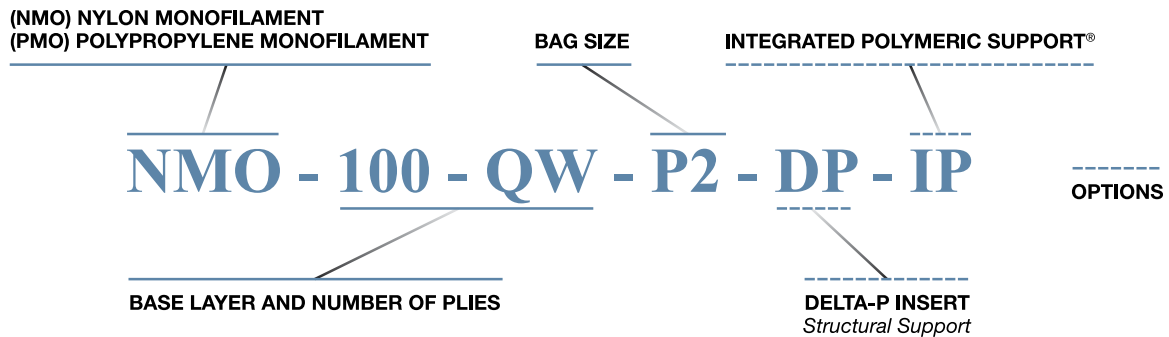

EXAMPLES	FILTRATION RANGE (µm)
NMO-40-QW-P2	40 µm – 14 µm
NMO-40-EW-P2	40 µm – 4 µm
NMO-40-XW-P2	40 µm – 2 µm
NMO-40-XII-P2	40 µm – 1 µm
PMO-100-QW-P2	100 µm – 37 µm
PMO-100-SW-P2	100 µm – 19 µm
PMO-100-EW-P2	100 µm – 10 µm
PMO-100-XW-P2	100 µm – 5 µm

MICRON RATINGS ACHIEVED FROM CONFIGURATION OF LAMINATED LAYERS												
MATERIAL MICRON RATING	NUMBER OF PLYS											
	DW 2	TW 3	QW 4	5	SW 6	7	EW 8	9	XW 10	11	XII 12	XIV 14
40	28.8	20.7	14.9	10.7	7.7	5.6	4.0	2.9	2.1	1.5	1.1	0.6
65	46.8	33.7	24.3	17.5	12.6	9.1	6.5	4.7	3.4	2.4	1.8	0.9
100	72.0	51.8	37.3	26.9	19.3	13.9	10.0	7.2	5.2	3.7	2.7	1.4
150	108	77.8	56.0	40.3	29.0	20.9	15.0	10.8	7.8	5.6	4.0	2.1
200	144	104	74.6	53.7	38.7	27.9	20.1	14.4	10.4	7.5	5.4	2.8
400	288	207	149	107	77.4	55.7	40.1	28.9	20.8	15.0	10.8	5.6
600	432	311	224	161	116	83.6	60.2	43.3	31.2	22.5	16.2	8.4
800	576	415	299	215	155	111	80.2	57.8	41.6	30.0	21.6	11.2

# ACCUFIT® WELDED - IP LIQUID FILTER BAGS

## IP Series - Integrated Polymeric Support®

### Polypropylene Felt Liquid Filter Bags

P2 SIZE: 7" Dia. x 32" L	
MODEL	DESCRIPTION
P-001-P2-IP	1 Micron, Size #2-IP
P-005-P2-IP	5 Micron, Size #2-IP
P-010-P2-IP	10 Micron, Size #2-IP
P-025-P2-IP	25 Micron, Size #2-IP
P-050-P2-IP	50 Micron, Size #2-IP
P-100-P2-IP	100 Micron, Size #2-IP
P-200-P2-IP	200 Micron, Size #2-IP

P1 SIZE: 7" Dia. x 16" L	
MODEL	DESCRIPTION
P-001-P1-IP	1 Micron, Size #1-IP
P-005-P1-IP	5 Micron, Size #1-IP
P-010-P1-IP	10 Micron, Size #1-IP
P-025-P1-IP	25 Micron, Size #1-IP
P-050-P1-IP	50 Micron, Size #1-IP
P-100-P1-IP	100 Micron, Size #1-IP
P-200-P1-IP	200 Micron, Size #1-IP

## Accufit Welded IP Series-Integrated Polymeric Support®

### Materials of Construction - 100% Polypropylene:

Needle Felt Filter Media  
Polypropylene Support Layer  
Non Woven Spun Bond Jacket  
*Zero-Bypass®* Collar

- Nominally rated solids retention
- Each Bag individually wrapped for cleanliness
- Sustains temperatures up to 180°F

The **IP** Jacket contains a structural layer which is ultrasonically laminated to the exterior of the polypropylene needled felt, to enhance its strength. Compared to standard felt filter bags, under similar field conditions, the **IP** Support Jacket results in:

- Increased Flow Rates by 40%
- Longer Run Times
- Enhanced Solids Loading
- Sustains 50% greater differential pressure before change-out is required
- Elimination of fiber migration downstream

P4 SIZE: 4" Dia. x 14" L	
MODEL	DESCRIPTION
P-001-P4-IP	1 Micron, Size #4-IP
P-005-P4-IP	5 Micron, Size #4-IP
P-010-P4-IP	10 Micron, Size #4-IP
P-025-P4-IP	25 Micron, Size #4-IP
P-050-P4-IP	50 Micron, Size #4-IP
P-100-P4-IP	100 Micron, Size #4-IP
P-200-P4-IP	200 Micron, Size #4-IP

P5 SIZE: 4" Dia. x 24" L	
MODEL	DESCRIPTION
P-001-P5-IP	1 Micron, Size #5-IP
P-005-P5-IP	5 Micron, Size #5-IP
P-010-P5-IP	10 Micron, Size #5-IP
P-025-P5-IP	25 Micron, Size #5-IP
P-050-P5-IP	50 Micron, Size #5-IP
P-100-P5-IP	100 Micron, Size #5-IP
P-200-P5-IP	200 Micron, Size #5-IP

Order in multiples of 50 pieces (minimum).  
Please order carefully, as filter bags are not returnable.

### Accufit Welded- IP Series Liquid Filter Bags Feature:

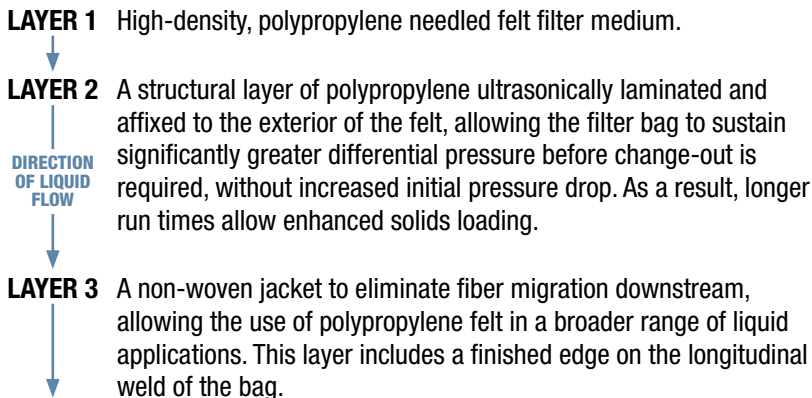

### Product Highlights

- **Fully welded Construction** Ultrasonically welded seams prevent solids, larger than the micron rating of the media, from bypassing the filter bag. Conventional filter bags are sewn, allowing particles to bypass through the needle holes of seams.
- **Zero-Bypass Bag Collar** The *Zero-Bypass* Collar provides an optimum compression seal, when used in a *Filtration Systems* filter vessel. When the filter bag is under elevated pressure, the flanged bag collar prevents bypass of unfiltered liquid.
- **Elevated Filter Bag Handles** A dual handle lift-out, located above the liquid level, eliminates contact with dirt and unfiltered materials and allows quick filter bag removal for replacement.



## ACCUFIT® WELDED SUPERBOND® LIQUID FILTER BAGS

Multi-layer, laminated filter bags provide superior particle removal efficiencies for a broad range of industrial filtration applications....

**ELC® - ENGINEERED LAMINATED COMPOSITE ~ CLEAN, UNIFORM and STABLE ~  
~DESIGNED FOR CONSISTENT AND PREDICTABLE RESULTS~  
AVAILABLE IN 100% FDA COMPLIANT POLYPROPYLENE or NYLON**

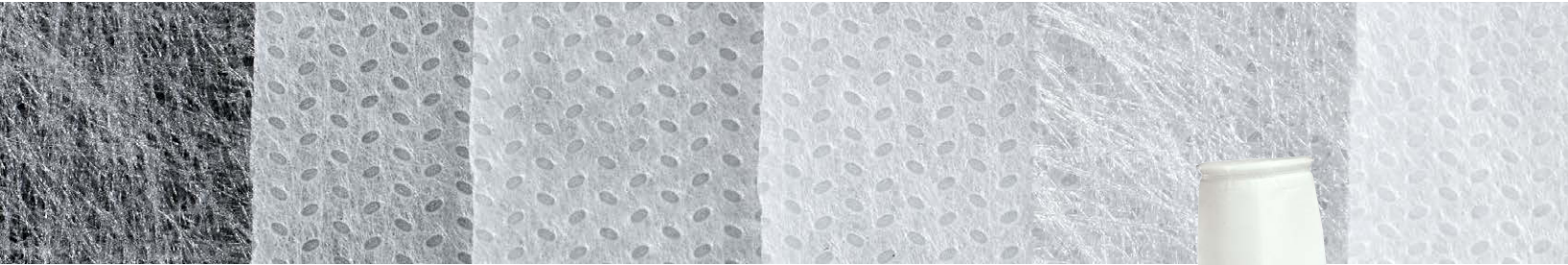

### Features

- *Accufit Welded SuperBond* is designed as the superior alternative to commodity-grade, felt filter bags.
- Designed to provide predictable performance results with 90% efficiency ratings.
- Ultrasonically Welded, Composite Layer Design for increased surface area and precise particle retention.
- No stitching holes like those found in other, sewn liquid filters.
- Longer lasting with significantly improved efficiencies over and above felt filter bags.
- IP Series - *Integrated Polymeric Support* structural layer for enhanced strength and support. Prevents fiber migration downstream.
- *Zero-Bypass* Compression Collar prevents bypass and sealing issues.

### Specifications

- Manufactured using Multi-Layer, Thermally Bonded Continuous Filament Depth Media in **Polypropylene** or **Nylon**.
- 100% FDA compliant materials, according to CFR Title 21. Silicone free.
- IP - *Integrated Polymeric Support*® support layer; non-fiber-shedding.
- Suggested maximum differential pressure: 35 psi / 2.4 bar
- Maximum operating temperature: Polypropylene 180°F / 82°C, Nylon 340°F / 171°C
- Suggested maximum flow rate: 90 gpm (water, P2 size)
- Available in standard industry sizes: P1 (7"dia x 16"L), P2 (7"dia x 32"L), P3 (4"dia x 9"L), P4 (4"dia x 14"L), P5 (4"dia x 24"L)
- Available micron ratings: 1, 5, 10, 25, 50, 100

### Model Number Coding

**SB-Pxxx-P2-IP** (xxx = micron rating) 100% FDA POLYPROPYLENE COMPONENTS

**SB-Nxxx-P2-IP** (xxx = micron rating) 100% FDA NYLON (N6) COMPONENTS



# ULTRAFIT® WELDED High Performance Liquid Filter Bags

Absolute Rated, Graded-Density, Composite Layer Design Technology™

ULTRAFIT 500	
MODEL	DESCRIPTION
500-P000-P2-EXP	<1- 0.5 Micron, Size #2
500-P001-P2-IP	1 Micron, Size #2-IP
500-P002-P2-IP	2 Micron, Size #2-IP
500-P005-P2-IP	5 Micron, Size #2-IP
500-P010-P2-IP	10 Micron, Size #2-IP
500-P025-P2-IP	25 Micron, Size #2-IP
500-P050-P2-IP	50 Micron, Size #2-IP

ULTRAFIT 100	
MODEL	DESCRIPTION
100-P001-P2-IP	1 Micron, Size #2-IP
100-P002-P2-IP	2 Micron, Size #2-IP
100-P005-P2-IP	5 Micron, Size #2-IP
100-P010-P2-IP	10 Micron, Size #2-IP
100-P025-P2-IP	25 Micron, Size #2-IP
100-P050-P2-IP	50 Micron, Size #2-IP
100-P100-P2-IP	100 Micron, Size #2-IP
100-P200-P2-IP	200 Micron, Size #2-IP

### Available Sizes:

**P2 Size** = 7" Dia. x 32" Long

**P1 Size** = 7" Dia. x 16" Long

Order in multiples of 20 pieces (minimum).  
Please order carefully, as filter bags are not returnable.

### Available Sizes:

**P2 Size** = 7" Dia. x 32" Long

**P1 Size** = 7" Dia. x 16" Long

**P4 Size** = 4" Dia. x 14" Long

**P5 Size** = 4" Dia. x 24" Long

## Ultrafit Welded 500

For applications demanding both high loading and efficiency, the *Ultrafit* Welded 500 Filter Bag has the unique ability to effectively filter liquids where particles vary in both size and distribution. The *Ultrafit* 500 Filter Bag consists of graded-density layers of melt-blown polypropylene, serving as a primary upstream filter. Separately jacketed, this pre-filter collects larger particles, preventing them from prematurely blinding the media below. As fluid progression continues downstream, redundant layers of absolute-rated microfiber capture finer particles, assuring filtration efficiency levels of at least 99% at the micron ratings available.

## Ultrafit Welded 100

The *Ultrafit* Welded 100 liquid Filter Bag is ideally suited for batch or smaller applications, or as a final filter where the range of particle size is narrower and more consistent. This product is designed to provide highly efficient liquid filtration for applications requiring consistent levels of purity. The *Ultrafit* 100 filtering membrane is constructed of FDA compliant, melt-blown polypropylene microfiber. The use of absolute-rated material achieves 97% filtration efficiency at the micron ratings available. Additional layers of non-woven spunbond are used to jacket the filtering membrane, providing support to the product and minimizing fiber migration downstream. The result is a superior product at an economical price.

## Ultrafit Welded 500-EXP

The *Ultrafit* 500- EXP filter bag consists of multiple layers of the same micron rating for applications requiring sub-micron filtration. Exponential layers improve capture rates and ensure filtration efficiency levels of at least 99% at the micron ratings available.

## IP - Integrated Polymeric Support

IP is a structural layer of ultrasonically laminated to the internal composite of the *Ultrafit* Welded Liquid Filter Bag. *Integrated Polymeric Support* allows the filter bag to sustain significant differential pressure before change-out is required, without increasing initial pressure drop. Longer run times allow enhanced solids loading.

*Integrated Polymeric Support* is a standard feature of the *Ultrafit* Welded 100, 500, 500 EXP, 800 and Nylon Series filter bags.

## NOTICE

**Filtration occurs by capturing particles throughout the depth of the media. As a result, single-use filter media is disposable and cannot be washed or reused.**

## ULTRAFIT 800, SUB-MICRON RATED

MODEL	DESCRIPTION	MODEL	DESCRIPTION
800-P02-P2-EXP	0.2 Micron, Size #2	800-P02-P1-EXP	0.2 Micron, Size #1
800-P04-P2-IP	0.4 Micron, Size #2	800-P04-P1-IP	0.4 Micron, Size #1
800-P06-P2-IP	0.6 Micron, Size #2	800-P06-P1-IP	0.6 Micron, Size #1
800-P08-P2-IP	0.8 Micron, Size #2	800-P08-P1-IP	0.8 Micron, Size #1

Order in multiples of 20 pieces (minimum).  
Please order carefully, as filter bags are not returnable.

## Ultrafit Welded 800

Ideal for high-purity and critical liquid process applications, *Ultrafit* Welded 800 Filter Bags achieve 99.98% efficiency (beta 5000), at ratings less than 1 micron. Filter Bags are individually wrapped for cleanliness, and packaged 20 pieces per case.

### Product Applications

- Micro-filtration for Industrial and Process Liquids
- Pharmaceutical, Biological, Electronic and Nuclear Applications
- Pre-filtration for Reverse Osmosis Membranes and Expensive Cartridges
- Filtration of Surface Water and Groundwater
- Recycling of Wastewater and Reclaimed Water

### Product Features

- Absolute Rated Performance... *99.98% efficient, down to 0.2 micron*
- 100% FDA Compliant Polypropylene Materials
- Graded-Density, Composite Layer Design... *allows enhanced solids loading*
- Fully Welded Ultrasonic Construction... *eliminates solids bypass*
- *Integrated Polymeric Support... provides superior mechanical strength*
- *Zero-Bypass Collar... assures an optimum compression seal*

## ULTRAFIT NYLON

MODEL	DESCRIPTION	MODEL	DESCRIPTION
500-N07-P2-EXP	< 1 Micron, Size #2	500-N07-P1-EXP	< 1 Micron, Size #1
500-N001-P2-IP	1 Micron, Size #2	500-N001-P1-IP	1 Micron, Size #1
500-N005-P2-IP	5 Micron, Size #2	500-N005-P1-IP	5 Micron, Size #1
500-N010-P2-IP	10 Micron, Size #2	500-N010-P1-IP	10 Micron, Size #1
500-N025-P2-IP	25 Micron, Size #2	500-N025-P1-IP	25 Micron, Size #1
500-N050-P2-IP	50 Micron, Size #2	500-N050-P1-IP	50 Micron, Size #1

Order in multiples of 20 pieces (minimum).  
Please order carefully, as filter bags are not returnable.

## Ultrafit Nylon

### Product Features

- Thermally and Chemically compatible with a broad range of applications where Polypropylene is not suitable
- Suitable for Sanitization, Autoclaving or in-Situ Steam Sterilization
- 100% FDA Compliant Nylon Materials
- No mildew or bacterial effects
- Abrasion resistant
- Efficiency Ratings of at least 99.9% (beta 1000) at the micron ratings available.
- Ideal for high temperature applications, up to 340°F
- Melt-Blown Nylon 6 Microfiber Filtering Membrane
- Long-Strand, thermally bonded continuous filament support layers
- IP - *Integrated Polymeric Support*
- *Zero-Bypass Collar: Nylon, 7.125" OD*

# ULTRAFIT WELDED – AMT™ SERIES

## Antimicrobial Technology (AMT) High Performance Liquid Filter Bags

P2 SIZE: 7" Dia. x 32" L	
MODEL	DESCRIPTION
AMT-P04-P2-IP	0.4 Micron, Size #2
AMT-P06-P2-IP	0.6 Micron, Size #2
AMT-P08-P2-IP	0.8 Micron, Size #2
AMT-P001-P2-IP	1 Micron, Size #2
AMT-P003-P2-IP	3 Micron, Size #2
AMT-P005-P2-IP	5 Micron, Size #2

P1 SIZE: 7" Dia. x 16" L	
MODEL	DESCRIPTION
AMT-P04-P1-IP	0.4 Micron, Size #1
AMT-P06-P1-IP	0.6 Micron, Size #1
AMT-P08-P1-IP	0.8 Micron, Size #1
AMT-P001-P1-IP	1 Micron, Size #1
AMT-P003-P1-IP	3 Micron, Size #1
AMT-P005-P1-IP	5 Micron, Size #1

### Available Sizes:

**P2 Size** = 7" Dia. x 32" Long

**P1 Size** = 7" Dia. x 16" Long

Order in multiples of 20 pieces (minimum).  
Please order carefully, as filter bags are not returnable.

### Standard Features and Materials of Construction

- Multi-Layer, High Performance Liquid Filter Bag
- Graded Density, *Composite Layer Design Technology™*
- Antimicrobial Agent incorporated into the final filtering layers of the Bag
- 99.98% efficiency ratings (beta 5000)
- Materials of construction: 100% FDA Compliant Polypropylene
- Single-use, disposable Filter Bag

### Benefits of Antimicrobial Technology

- Antimicrobial agent inhibits the growth of broad spectrum bacteria, fungi, protozoa and yeast on the treated layers
- Antimicrobial agent lasts the life of the filter
- Non-Toxic and insoluble in water

### What are some uses for *Ultrafit* welded-AMT Series High Performance Filter Bags?

When properly installed in a *Filtration Systems Over-The-Top* design housing, *Ultrafit* Welded-AMT Series filter bags are useful in filtering many types of liquids, including water, transformer cooling oil, synthetic oil, lubricants, paints and other water-based liquids, when prevention of fluid contamination during the filtering process is important to the final product.

### Why is Antimicrobial Protection important for my filtering process?

Microorganisms can contaminate liquids causing spoilage, odor, degradation and reduced shelf life of products. Other effects of contamination may include changes in viscosity or pH, discoloration, gassing during processing or swelling of finished product containers. During the filtering process the formation of biofilms may inhibit liquid flow, contaminate or corrode process piping and affect heat exchange.

### How does Antimicrobial Technology work?

Antimicrobial additives disrupt the metabolic function of thin walled, aerobic and anaerobic microorganisms, inhibiting their ability to function, grow and reproduce on the filter media.

### How is the Antimicrobial agent built into the media?

The antimicrobial agent is incorporated into the polymeric voids of the polypropylene fiber, without affecting the physical properties of the fiber. The submicron-sized particles migrate to the surface of the fiber, where they become an integral part of the microfiber. Since it is part of the fiber, not a surface coating, it will not wash or wear out. The antimicrobial agent is insoluble in water and lasts the life of the filter.

### Is it safe?

Antimicrobial agents only attack thin-walled cells. Human and animal cells are thick-walled, and are therefore impermeable to the antibacterial additive. The antimicrobial agent, Triclosan (Chlorinated Phenoxy Compound), is registered with the EPA as a safe, non-toxic product.



**The *Ultrafit* Welded- AMT Filter Bag does not protect users or others against food-borne (or disease causing) bacteria. Mechanical Manufacturing Corporation, *Filtration Systems* Division is not making any health claims for this product.**

# APX® HIGH-CAPACITY ELEMENT

## Large Diameter, Drop-In Cartridge Filter Element

Advanced filter technology specifically designed for Over-The-Top Vessel Systems



### Features

- Inside to outside flow configuration allows the finest particle retention to have the greatest allocation of surface area
- Graded-design, controlled porosity depth media for precise particle retention and consistent performance
- Deep-pleated design and structurally reinforced upstream/downstream for product stability
- Long cycle times and enhanced life make them more economical than using standard cartridge filters
- Greater surface area due to larger physical size compared to other competitive products, providing lower cost-per-gallon to filter
- Retrofits most standard #2, #4 & #5 size filter housings, avoiding the capital expense of new equipment
- Easy to use drop-in design requires no support basket for use, further reducing pressure buildup
- Filtered solids are contained within the element, so removal of the cartridge fully eliminates vessel cleaning

### Specifications

- Available in three sizes: **APX-728:** 7" Dia. x 28" L **APX-412:** 4" Dia. x 12" L **APX-422:** 4" Dia. x 22" L
- Materials of Construction: 100% Polypropylene
- All materials are FDA listed for food contact in Title 21 of U.S. Code of Federal Regulations
- Absolute-rated efficiency of 99% available in seven-micron ratings: 0.5, 1, 5, 10, 25, 50 and 100. (ASTM F 795 Test)
- Maximum Flow Rate (water) **APX-728:** 90gpm **APX-412:** 20gpm **APX-422:** 30gpm
- Maximum Operating Temperature 176°F/80°C
- Maximum Recommended Change-out Differential 35 psid
- Maximum Differential Pressure of the APX element 50 psid at 68°F and 45 psid at 120°F
- *PurSeal*® flange provides hydrostatic compression seal when used in our *Over-The-Top* design housings, eliminating bypass of unfiltered liquid downstream
- EPR/EPDM standard gasket material



Easy to use drop-in design requires no support basket.



APX Filter Element combines large surface area and high flow rate to provide massive solids loading with longer run times in a unique, oversized drop-in design.

# FILTER MEDIA PRODUCT SPECIFICATIONS

LIQUID FILTER BAG COMPONENTS & SPECIFICATIONS	SERIES	ACCUFIT® SuperBond® IP	ACCUFIT Expanded Media	ULTRAFIT® 100 IP	ULTRAFIT 500 IP	ULTRAFIT 500 EXP	ULTRAFIT 800 IP	ULTRAFIT 800 EXP	ULTRAFIT-NYLON IP	ULTRAFIT-NYLON EXP	ULTRAFIT AMT	ULTRAFIT Test Bag
	Thermally Bonded Continuous Filament		•		•	•	•	•	•	•	•	•
Laminated Monofilament Layers, Polypropylene or Nylon			•									
Meltblown Microfiber, Polypropylene (P) or Nylon (N)				P	P	P	P	P	N	N	P	P
Graded-Density, Composite Layer Design Technology™				•	•		•		•		•	•
IP-Integrated Polymeric Support®		•		•	•	•	•	•	•	•	•	•
Sieve Layer		•		•	•	•	•	•	•	•	•	•
FDA Compliant Materials		•	•	•	•	•	•	•	•	•	•	•
Zero-Bypass® Bag Collar with Dual Lift-Out Handles		•	•	•	•	•	•	•	•	•	•	•
Efficiency Rating	Nominal	Nominal	97%	99%	99%	99.98%	99.98%	99.9%	99.9%	99.98%	99%	99%
Maximum Temperature (deg. F)	180°(P) 340°(N)	180°(P) 340°(N)	180°	180°	180°	180°	180°	340°	340°	180°	180°	180°
Available Sizes	1,2 3,4,5	1,2,4,5	1,2,4,5	1,2	1,2	1,2,4,5	1,2,4,5	1,2	1,2	1,2	2	2

MICRON RATING AVAILABILITY																	
MICRON RATING	.2	.4	.6	.8	<1	1	2	5	10	20	25	40	50	100	200	400	600
<b>NOMINALLY RATED FILTER BAGS</b>																	
ACCUFIT® SuperBond® IP						•		•	•		•		•	•			
ACCUFIT Expanded Media					•	•	•	•	•	•	•	•	•	•	•	•	•
<b>ABSOLUTE RATED, HIGH PERFORMANCE FILTER BAGS</b>																	
ULTRAFIT® 100 IP						•	•	•	•		•		•	•	•		
ULTRAFIT 500 IP						•	•	•	•		•		•				
ULTRAFIT 500 EXP					•												
ULTRAFIT 800 IP		•	•	•													
ULTRAFIT 800 EXP	•																
ULTRAFIT-NYLON IP						•		•	•		•		•				
ULTRAFIT-NYLON EXP					•												
ULTRAFIT AMT		•	•	•		•		•									
<b>LARGE DIAMETER DROP-IN CARTRIDGE FILTER</b>																	
APX HIGH-CAPACITY ELEMENT					•	•		•	•		•		•	•			

## MAXIMUM FLOW RATES

gpm (water)	FILTER BAG SIZE			
	P2	P1	P4	P5
<b>ACCUFIT® SuperBond® IP</b>	90	75	35	
<b>ACCUFIT Expanded Media</b>	120	75	40	
<b>ULTRAFIT® 100 IP</b>	60	45	16	
<b>ULTRAFIT 500 IP</b>	30	15	–	–
<b>ULTRAFIT 500 EXP</b>	40	30	–	–
<b>ULTRAFIT 800 IP</b>	20	12	6	10
<b>ULTRAFIT 800 EXP</b>	15	8	3	6
<b>ULTRAFIT-NYLON IP</b>	40	25	–	–
<b>ULTRAFIT-NYLON EXP</b>	25	15	–	–
<b>ULTRAFIT AMT</b>	23	12	6	10

APX HIGH-CAPACITY ELEMENT	ELEMENT SIZE		
	728	412	422
	90	20	30

## MAXIMUM DIFFERENTIAL PRESSURE

(psig) Initial Pressure plus...	FILTER BAG SIZE			
	P2	P1	P4	P5
<b>ACCUFIT® SuperBond® IP</b>	30	30	30	30
<b>ACCUFIT Expanded Media</b>	35	35	35	35
<b>ULTRAFIT® 100 IP</b>	34	34	34	34
<b>ULTRAFIT 500 IP</b>	34	34	–	–
<b>ULTRAFIT 500 EXP</b>	34	34	–	–
<b>ULTRAFIT 800 IP</b>	30	30	30	30
<b>ULTRAFIT 800 EXP</b>	30	30	30	30
<b>ULTRAFIT-NYLON IP</b>	24	24	–	–
<b>ULTRAFIT-NYLON EXP</b>	34	34	–	–
<b>ULTRAFIT AMT</b>	30	30	30	30

APX HIGH-CAPACITY ELEMENT	ELEMENT SIZE		
	728	412	422
	35	35	35

## GENERAL CHEMICAL COMPATIBILITY OF POLYPROPYLENE AND NYLON

CLASSIFICATION	TYPICAL EXAMPLES	POLYPROPYLENE	NYLON
<b>BASES (ALKALIES)</b>	Amines, Ammonium Hydroxide, Potassium Hydroxide, Sodium Hydroxide	Generally Compatible	Testing Recommended
<b>BRINES</b>	Calcium Chloride, Potassium Chloride, Sodium Bromide, Sodium Chloride	Generally Compatible	Generally Compatible
<b>INORGANIC ACIDS</b>	Boric, Dilute Nitric, Dilute Sulfuric, Hydrochloric, Phosphoric	Generally Compatible	Testing Recommended
<b>ORGANIC SOLVENTS</b>	Alcohols, Amides Cellosolves, Esters, Esthers, Glycols, Ketones	Testing Recommended	Generally Compatible
	Aromatics (Benzene, Toluenes, Xylenes)	Not Recommended	Generally Compatible
	Petroleum Products (Aviation Gasoline, Diesel Fuel, Kerosene)	Not Recommended	Generally Compatible
	Hydrocarbons (Fats, Hexane, Octane, Oils, Petroleum Ether)	Testing Recommended	Generally Compatible
	Halogenated Hydrocarbons (Methylene Chloride, Perchloroethylene)	Testing Recommended	Testing Recommended
<b>SALT SOLUTIONS</b>	Aluminum Chloride, Sodium Nitrate, Sodium Sulfate	Generally Compatible	Generally Compatible
<b>WATER</b>	Ambient (Nylon is not recommended for hot water)	Generally Compatible	Generally Compatible
Maximum temperature limits for any fluid. Requires evaluation on an individual basis.		180° F	340° F

### WARNING

**Important Note on Chemical Compatibility:** The information presented in this table is based on exposure at room temperature and is for general guidance only. In most cases, the use of specific filtering material, such as polypropylene, nylon, or cellulose, can be safely recommended without special testing. However, since many factors can affect the chemical resistance of a given product, the user under actual on-site operating conditions must determine filter bag compatibility. Factors such as degree of concentration of a substance in a fluid, temperature, and duration of exposure should be considered, as they may compromise the structural integrity and performance of the filter media.

## STANDARD TERMS & CONDITIONS OF SALE

### Domestic Payment Terms

**Open Account Terms are NET 30 DAYS, after credit approval. Until credit has been established, terms are payment by credit card, or advance payment.** We accept Master Card, VISA and American Express. Accounts are considered delinquent 30 days after due date, and are subject to suspension and collection. If this should occur, the buyer will be responsible for all collection costs, filing fees, and attorney's fees. Venue for such action shall be in Broward County, Florida. **Filtration Systems reserves the right to limit or extend credit.**

All pricing is in U.S. Dollars, payable in U.S. Funds on a U.S. bank. Sales and shipments within the State of Florida will be subject to Florida Sales Tax. A valid Certificate of Resale must be furnished if no sales tax is to be collected.

### International Sales and Terms

International Orders must be paid IN ADVANCE by Credit Card or T/T Wire. Irrevocable Letters of Credit (L/C) are not accepted. Export order processing or production will commence upon receipt of funds. All shipping arrangements should be made by the buyer, and orders will be shipped FREIGHT COLLECT, via buyer's Freight Forwarder.

**All International/Export orders will be subject to an export processing fee (one per shipment). Fee determined by required documentation, courier charges and packaging requirements.**

**All duties, taxes, documentation and bank charges are the responsibility of the buyer.**

### Order and Shipment Policies

**All Purchase Orders must be submitted in writing prior to processing and shipping. Orders can be faxed to 954-572-3401, mailed, or emailed to FSorders@FiltSys.com**

#### Minimum Order Requirements

- 1 Minimum order quantity for Filter Bags is one case (consult factory).
- 2 For all other items, minimum order is \$100.00.

#### Custom Orders

Please consult factory for custom items and/or modifications. Payment for custom items or modified equipment may be required prior to fabrication. **CUSTOM ITEMS OR MODIFIED EQUIPMENT ARE NOT RETURNABLE.**

### Freight Terms

**All shipments are FOB Plant, Sunrise, Florida, USA. All shipping charges are the responsibility of the buyer. Orders can only be drop shipped within the Continental United States, and Hawaii.**

**Filtration Systems will NOT prepay airfreight charges.** Air shipments will be sent FREIGHT COLLECT. Please provide account number (FedEx, UPS, etc.) to bill airfreight charges.

### Merchandise Returns

**Filter Bags, Cartridge Filters, Baskets, O-Rings, HALAR Coated Vessels and Accessories, Epoxy Coated Vessels and Custom Items or Modified Equipment are NOT returnable.**

Authorization and the issuance of an RGA Number (Return Goods Authorization Number) MUST be obtained before returning any merchandise. **Returned goods are to be shipped freight prepaid and are subject to a 30% restocking charge.** Outside of carton MUST be labeled with our RGA number. Any item returned without an RGA number or sent with incorrect freight classification number will be refused.



## WARRANTY / LIMITATION OF LIABILITY

### Warranty

*Filtration Systems* warrants its products to be free from defects in workmanship for a period of one year from the date of purchase, when used in accordance with our specific guidelines. Our only obligation and a customer's remedy, subject to our inspection and evaluation, shall be to replace the product or refund the purchase price.

### Limitation of Liability

*Filtration Systems* shall not be held responsible or liable for any loss resulting from the resale, direct or indirect misuse, incidental or consequential damages, arising out of the use of this product. Not all questions or issues may have been addressed in this manual. If you require any additional assistance or technical information, please contact our Customer Service Department.

### Lethal Service

*Filtration Systems* vessels are not designed for lethal service. "Lethal Service" refers to vessels containing lethal substances, poisonous gases or liquids of such a nature that a very small amount of the gas or vapor of the liquid (mixed or unmixed) is dangerous to life when inhaled. In addition, substances of this nature that are stored under pressure, or may generate pressure if stored in a closed vessel, are considered lethal.

### Product Identification

All *Filtration Systems* filter vessels have a unique serial number that can be identified by our factory. Nameplates, specifying both the serial number and maximum allowable pressure and temperature rating are permanently affixed to all housings.

Removal of the nameplate voids the product of any warranty and eliminates future identification of the product.

## PRODUCT SPECIFICATIONS / INTELLECTUAL PROPERTY

### Product Specifications

With over 50 years of industry expertise and proven performance, *Filtration Systems* offers quality products at responsible prices. We continually strive to improve our products through ongoing research and development; therefore, we reserve the right to change specifications without notice.

### Intellectual Property

*Filtration Systems* products offer exclusive manufacturing technology. Our company is committed to protecting its patents, trademarks, and proprietary rights from those who would wrongfully use them.

### Partial Listing of Registered Trademarks of Mechanical Manufacturing Corporation

***Over-The-Top***<sup>®</sup>

***SAFEsystem***<sup>®</sup>

**Common Drain Manifold – CDM**<sup>™</sup>

**Dual Valve Linkage Mechanism – DVLM**<sup>™</sup>

***Bullet Bottom***<sup>®</sup> Basket

***Accufit***<sup>®</sup> Welded Liquid Filter Bags

***Accufit***<sup>®</sup> Welded ***SuperBond***<sup>®</sup>

***Ultrafit***<sup>®</sup> Welded Liquid Filter Bags

***APX***<sup>®</sup> High-Capacity Elements

***IP Integrated Polymeric Support***<sup>®</sup>

***EXP***<sup>®</sup> Series

***Composite Layer Design Technology***<sup>™</sup>

***ELC***<sup>®</sup> Engineered Laminate Composite

***AMT–Antimicrobial Technology***<sup>™</sup>

***TruSeam***<sup>®</sup> Technology

***Zero-Bypass***<sup>®</sup> Collar

***PurSeal***<sup>®</sup> Collar

***METRIX***<sup>®</sup> Collar

### Other Trademarks

**Halar**<sup>®</sup> is a registered Trademark of Solvay

**Aflas**<sup>®</sup> is a registered Trademark of Asahi Glass Co. Ltd.

**Neoprene**<sup>®</sup>, **Teflon**<sup>®</sup>, and **Viton**<sup>®</sup> are Registered Trademarks of E.I. DuPont Company

# FILTRATION SYSTEMS LIQUID FILTER HOUSINGS MODEL NUMBER CODING SYSTEM

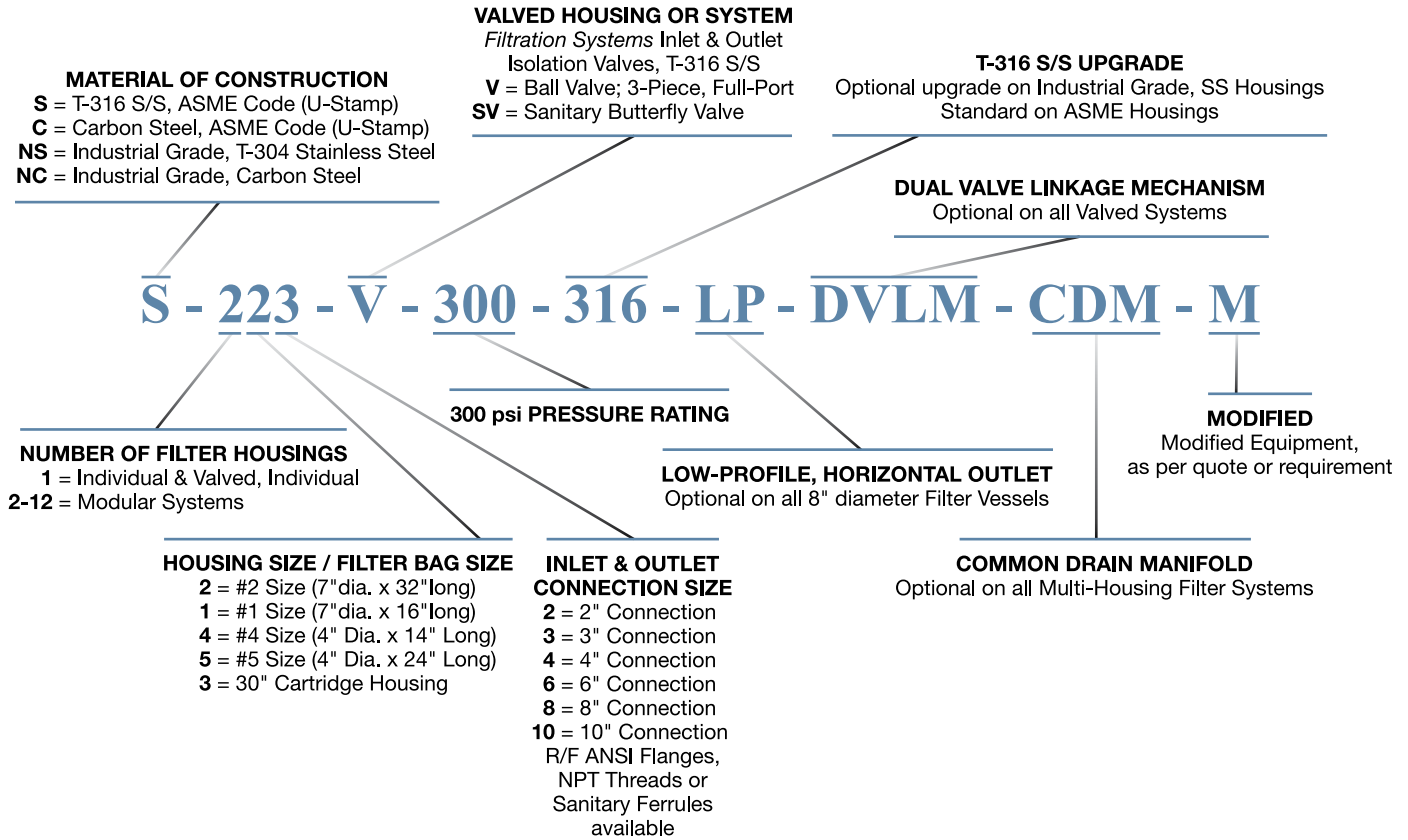

**SPARE PARTS MAY BE ORDERED FROM YOUR DISTRIBUTOR OR:**

## *Filtration Systems*

**Division of Mechanical Mfg. Corp.**

**10304 NW 50th Street  
 Sunrise, FL 33351**

**Phone: 954-572-2700  
 Fax: 954-572-3401**

**[www.filtrationsystems.com](http://www.filtrationsystems.com)**





We are committed to satisfying our customer's diverse needs with personal service and prompt delivery.

Companies that invest in the refinement of their liquid filtration processes are rewarded with higher quality products, increased productivity and reduced labor costs.



We have extensive experience in the areas of Process and Industrial Filtration, Microfiltration and Pre-filtration.



The cornerstone of *Filtration Systems* philosophy is Customer Satisfaction.

Our commitment extends to product quality, prompt delivery, and system recommendation.

We serve the following industries and their distributors:

- Chemical & Petrochemical Processing
- Pharmaceutical, Cosmetic & Biotechnology Processing
- Water Treatment, Purification & Reclamation
- Food, Beverage & Fermentation
- Electronic Components, Photo & Audio Visual
- Surface Technology, Cleaning Machines, Nuclear
- Critical Liquid Process Applications

With over 50 years of industry experience, *Filtration Systems* has a reputation as a market leader, manufacturing industrial liquid filter products of superior quality and design.



Our vessels and filter media are specifically designed to work together as a system, maximizing efficiency.

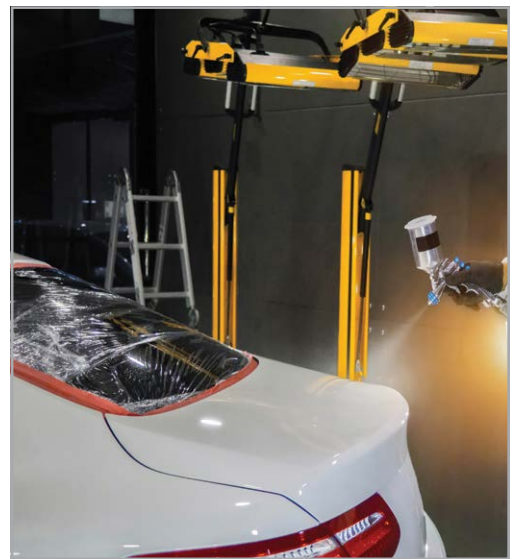

*Filtration Systems* vessels and filter media are widely used throughout the world for liquid clarification and high-purity filtering applications.

# **Filtration Systems**

*Division of Mechanical Mfg. Corporation*

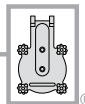

10304 N.W. 50th Street • Sunrise, FL 33351 USA

Tel: 954-572-2700 • Fax: 954-572-3401

[www.filtrationsystems.com](http://www.filtrationsystems.com)

**ISO 9001:2015 Certified**

©2025 Mechanical Manufacturing Corp.  
FS-10-1/25